

SIMATIC HMI

HMI devices Unified Basic Panels

Operating Instructions



<u>Preface</u>	
<u>Overview</u>	1
<u>Safety instructions</u>	2
<u>Mounting and connecting the device</u>	3
<u>Operating the device</u>	4
<u>Operating the Control Panel</u>	5
<u>Transferring data</u>	6
<u>Device maintenance and repair</u>	7
<u>Technical information</u>	8
<u>Technical Support</u>	A
<u>Markings and symbols</u>	B
<u>Abbreviations</u>	C

Legal information

Warning notice system

This manual contains notices you have to observe in order to ensure your personal safety, as well as to prevent damage to property. The notices referring to your personal safety are highlighted in the manual by a safety alert symbol, notices referring only to property damage have no safety alert symbol. These notices shown below are graded according to the degree of danger.

DANGER

indicates that death or severe personal injury **will** result if proper precautions are not taken.

WARNING

indicates that death or severe personal injury **may** result if proper precautions are not taken.

CAUTION

indicates that minor personal injury can result if proper precautions are not taken.

NOTICE

indicates that property damage can result if proper precautions are not taken.

If more than one degree of danger is present, the warning notice representing the highest degree of danger will be used. A notice warning of injury to persons with a safety alert symbol may also include a warning relating to property damage.

Qualified Personnel

The product/system described in this documentation may be operated only by **personnel qualified** for the specific task in accordance with the relevant documentation, in particular its warning notices and safety instructions. Qualified personnel are those who, based on their training and experience, are capable of identifying risks and avoiding potential hazards when working with these products/systems.

Proper use of Siemens products

Note the following:

WARNING

Siemens products may only be used for the applications described in the catalog and in the relevant technical documentation. If products and components from other manufacturers are used, these must be recommended or approved by Siemens. Proper transport, storage, installation, assembly, commissioning, operation and maintenance are required to ensure that the products operate safely and without any problems. The permissible ambient conditions must be complied with. The information in the relevant documentation must be observed.

Trademarks

All names identified by ® are registered trademarks of Siemens Aktiengesellschaft. The remaining trademarks in this publication may be trademarks whose use by third parties for their own purposes could violate the rights of the owner.

Disclaimer of Liability

We have reviewed the contents of this publication to ensure consistency with the hardware and software described. Since variance cannot be precluded entirely, we cannot guarantee full consistency. However, the information in this publication is reviewed regularly and any necessary corrections are included in subsequent editions.

Preface

Purpose of the operating instructions

These operating instructions contain information based on the requirements for mechanical engineering documentation. This information relates to the location, transport, storage, mounting, use and maintenance.

These operating instructions are intended for:

- Users
- Commissioning engineers
- Maintenance personnel

Observe especially the information in the "Safety instructions" (Page 17) section.

You can find more information in the TIA Portal Help.

Basic knowledge required

General knowledge of automation technology and process communication is needed to understand the operating instructions. Knowledge of personal computers and Microsoft operating systems is required.

Scope of the operating instructions

The operating instructions apply to the following HMI devices in conjunction with the software SIMATIC WinCC Unified V19 or higher:

Name	Type	Article number
MTP400 Unified Basic	4" device	6AV2123-3DB32-0AW0
MTP700 Unified Basic	7" device	6AV2123-3GB32-0AW0
MTP1000 Unified Basic	10" device	6AV2123-3KB32-0AW0
MTP1200 Unified Basic	12" device	6AV2123-3MB32-0AW0

ID Link for the digital type plate



The ID Link is a unique identifier in accordance with IEC 61406-1, which you will find in future as a QR code on your product and the product packaging.

You can recognize the ID Link from the frame, which has a black corner at the bottom right. The ID Link takes you to the digital type plate of your product.

Scan the QR code on the product or on the packaging label with a smartphone camera, a bar code scanner or a Read app. Call the relevant link.

In the digital type plate, you will find product data, manuals, Declarations of Conformity, certificates and other helpful information on your product.

Keeping this documentation

NOTICE
Manual belongs to the HMI device
This manual belongs to the HMI device and is also required for recommissioning. Store all supplied and supplementary documentation for the entire service life of the HMI device. Provide all stored documents to subsequent owners of the HMI device.

For digitally attached documentation:

1. After you receive your product, download the relevant documentation, at a time no later than the first assembly/commissioning. Use the following options for the download:
 - Technical Support (<https://support.industry.siemens.com>):
The documentation is assigned to the product via the article number. The article number can be found on the product and on the packaging label. Products with new, incompatible functions are given a new article number and documentation.
 - ID Link:
If your product carries an ID Link, you can recognize it as a QR code having a frame with a black corner at the bottom right. The ID Link takes you to the digital type plate of your product. Scan the QR code on the product or on the packaging label with a smartphone camera or a bar code scanner. Call the relevant ID Link.
2. Keep this version of the documentation.

Trademarks

The following designations marked with the registration symbol ® are registered trademarks of Siemens Aktiengesellschaft:

- HMI®
- SIMATIC®
- WinCC®

Style conventions

Text description	Example	Meaning
Text in quotation marks: "Text"	"Add screen"	<ul style="list-style-type: none"> • Terminology that appears in the user interface, for example dialog names, tabs, buttons, menu commands • Required inputs, for example, limits, tag values. • Path information
Text in quotation marks, separated by a 'greater than' symbol: "Text > Text"	"File > Edit"	Operating sequences, for example, menu commands, shortcut menu commands.
Texts in angle brackets: <Text>	<F1>, <Alt+P>	Keyboard operation
	<ip>, <date>, <time>	Tag values in URLs, path information, folder names, file names or in the user interface

Please observe notes labeled as follows:

Note

A note contains important information about the product described in the manual and its use, or a specific section of the manual to which you should pay particular attention.

Naming conventions

This document uses the following naming conventions.

Term	Applies to
Plant	<ul style="list-style-type: none"> • System • Machining center • One or more machines
HMI device, Device	<ul style="list-style-type: none"> • MTP400 Unified Basic • MTP700 Unified Basic • MTP1000 Unified Basic • MTP1200 Unified Basic
WinCC	SIMATIC WinCC Unified V19 or higher

In place of the full product name, the short product name without the suffix "Unified Basic" is also used, for example:

"MTP1200" in place of "MTP1200 Unified Basic"

Figures

This manual contains figures of the described devices. The figures can deviate from the delivered device in detail.

Picture components are marked with black position numbers on a white background:

①, ②, ③, ...

Steps in the figures are identified with white process numbers on a black background according to the sequence in which they have to be executed:

❶, ❷, ❸, ...

Table of contents

	Preface	3
1	Overview.....	11
1.1	Product description	11
1.2	Scope of delivery	12
1.3	Design of the devices	13
1.4	Interfaces	14
1.5	Accessories	14
1.6	The HMI device in the operating process	16
2	Safety instructions	17
2.1	General safety instructions.....	17
2.2	Security management for HMI devices	19
2.3	Data protection.....	19
2.4	Notes about usage.....	20
3	Mounting and connecting the device	22
3.1	Preparing for installation.....	22
3.1.1	Checking the delivery.....	22
3.1.2	Checking the operating conditions	22
3.1.3	Permitted mounting positions	23
3.1.4	Checking clearances	25
3.1.5	Preparing the mounting cutout	26
3.2	Mounting the device.....	27
3.2.1	Notes on installation.....	27
3.2.2	Positions of the mounting clips	28
3.2.3	Fastening the built-in device with mounting clips.....	29
3.3	Connecting the device	31
3.3.1	Notes on connection.....	31
3.3.2	Equipotential bonding	33
3.3.3	Connecting the power supply.....	35
3.3.4	Connecting the configuration PC.....	37
3.3.5	Connecting the controller	38
3.3.6	Connecting a USB device.....	39
3.3.7	Switching on, testing and switching off the device	41
3.3.8	Securing the cables.....	42
3.4	Removing the device.....	43
4	Operating the device	44
4.1	Operator input options	44

- 4.2 Important notes on touch screen 44
- 4.3 Supported gestures..... 47
 - 4.3.1 Supported gestures in the Control Panel..... 47
 - 4.3.2 Supported gestures in the runtime project 47
- 4.4 Using the screen keyboard 50
 - 4.4.1 The screen keyboards 50
 - 4.4.2 Control keys on the screen keyboard 53
- 4.5 Commissioning the HMI device 53
- 4.6 Web access to the HMI device 54
- 4.7 Notes on operation 58
- 5 Operating the Control Panel..... 59**
 - 5.1 Opening the settings 59
 - 5.2 Overview of functions..... 62
 - 5.3 System Properties 63
 - 5.3.1 Panel information 63
 - 5.3.2 Display 64
 - 5.3.3 Screensaver 65
 - 5.3.4 Update OS 66
 - 5.3.5 Reboot 68
 - 5.3.6 Performance 69
 - 5.4 Runtime Properties 70
 - 5.4.1 Project information 70
 - 5.4.2 Automatic runtime start..... 70
 - 5.4.3 Alarm persistency 71
 - 5.4.4 Web client 72
 - 5.4.5 Load project from storage 73
 - 5.5 Network and Internet..... 76
 - 5.5.1 Network settings 76
 - 5.6 Security 79
 - 5.6.1 User management 79
 - 5.6.2 Certificates 83
 - 5.6.3 Control panel access 87
 - 5.6.4 UMAC settings 88
 - 5.7 External Devices and Input..... 90
 - 5.7.1 Hardware interfaces..... 90
 - 5.7.2 Connected devices..... 91
 - 5.8 Language, Region and Formats 92
 - 5.8.1 Date and time..... 92
 - 5.9 Service and Commissioning 94
 - 5.9.1 Transfer..... 94
 - 5.9.2 Update OS 95
 - 5.9.3 Backup 97
 - 5.9.4 Restore 98
 - 5.9.5 Trace options..... 100

6	Transferring data	102
6.1	Overview	102
6.2	Operating modes	103
6.3	Using existing projects	104
6.4	Data transmission options	104
6.5	Setting the PG/PC interface	105
6.6	Transferring a project with WinCC	105
6.7	Backup and restore	108
6.8	Updating the operating system	111
6.8.1	Overview and important notes	111
6.8.2	Updating the operating system via WinCC	112
6.8.3	Resetting an HMI device to factory settings via ProSave	113
7	Device maintenance and repair.....	115
7.1	General information on maintenance and servicing	115
7.2	Cleaning the device front	115
7.2.1	Clean the glass front of the HMI device.	115
7.2.2	Notes on the clean screen	116
7.3	Using the maintenance mode	116
7.4	Spare parts and repairs	118
7.5	Recycling and disposal	118
8	Technical information.....	119
8.1	Software license agreements	119
8.2	Markings and approvals	119
8.3	Certificates	121
8.4	Standards and requirements	121
8.5	Electromagnetic compatibility	122
8.6	Mechanical ambient conditions.....	124
8.6.1	Transport and storage conditions	124
8.6.2	Operating conditions	124
8.7	Climatic ambient conditions.....	124
8.7.1	Transport and storage conditions	124
8.7.2	Operating conditions	125
8.7.3	Climate diagram	125
8.8	Information on insulation tests, protection class and degree of protection	126
8.9	Dimension drawings	127
8.9.1	Dimension drawings of the MTP400 Unified Basic	127
8.9.2	Dimension drawings of the MTP700 Unified Basic	127
8.9.3	Dimension drawings of the MTP1000 Unified Basic	128
8.9.4	Dimension drawings of the MTP1200 Unified Basic	129

8.10	Technical specifications	130
8.10.1	MTP400, MTP700 Unified Basic	130
8.10.2	MTP1000, MTP1200 Unified Basic	132
8.11	Description of the interfaces	134
8.11.1	DC24V X80	134
8.11.2	PROFINET (LAN) X1	134
8.11.3	USB X61/X62	134
8.12	Communication with controllers	135
8.13	Scope of functions with WinCC	137
A	Technical Support.....	140
A.1	Service and support	140
A.2	System alarms	141
A.3	Information about the manufacturer	141
B	Markings and symbols.....	142
B.1	Safety-relevant symbols	142
C	Abbreviations	144
	Glossary	145

Overview

1.1 Product description

SIMATIC HMI Unified Basic Panels offer you numerous options for implementing your innovative operating concepts.

In addition to significantly increased performance, the user benefits from the new possibilities of the Panels in conjunction with the SIMATIC WinCC Unified visualization software.

The industrial-grade, multi-touch glass front of all devices from 4" to 12" offers convenient operation with an impressive high-quality display.

The most important advantages at a glance:



- Maximum user-friendliness through better legibility as well as more brilliant colors and high contrast of the display, combined with significantly higher ruggedness of the multi-touch technology.
- Integrated functionality for all device sizes from 4" to 12".
- Increased hardware performance as well as higher system limits for significantly larger applications based on a panel-based system than before. High level of IT security to protect the system against hacker attacks through a proprietary operating system.
- Visualization based on SIMATIC WinCC Unified, the new web-based visualization system in the TIA Portal for scalable solutions for machine-level applications.

Features of the Unified Basic Panels

Enclosure	Rugged plastic enclosure
Mounting format	Mounting and operation in landscape and portrait format The respective format must be selected during the configuration of the user interface. The display orientation must also be changed in the Control Panel of the HMI device.
Interfaces	One Gigabit Ethernet interface Two USB ports USB 2.0 (Type A)
Display	High-resolution TFT display in widescreen format with 16 million colors Wide viewing angle Dimmable from 10 to 100%
Operation	Capacitive multi-touch screen

1.2 Scope of delivery

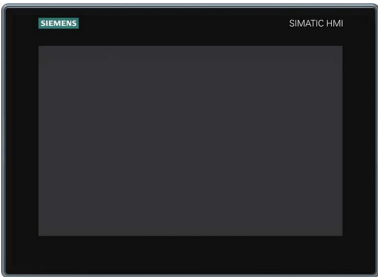
The scope of delivery of the HMI device includes the following components:

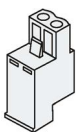
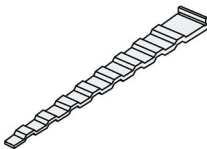
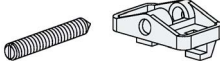
Name	Figure	Quantity	
HMI device		1	
Installation instructions (Quick Install Guide)		1	
Power supply connector		1	
Strain relief element	Plastic strain relief element 	2	
Mounting clips, plastic enclosure with set screw		4	MTP400
		6	MTP700
		12	MTP1000, MTP1200

1.3 Design of the devices

This section describes the design of the Unified Basic Panels, using the MTP1200 Unified Basic as an example. The other Unified Basic Panels differ in the size of the front, the interfaces being identical for all Unified Basic Panels.

Front view and side view



- ① Display and capacitive multi-touch screen
- ② Spring fasteners for easier mounting
- ③ Recesses for mounting clips
- ④ Mounting seal

Rear view

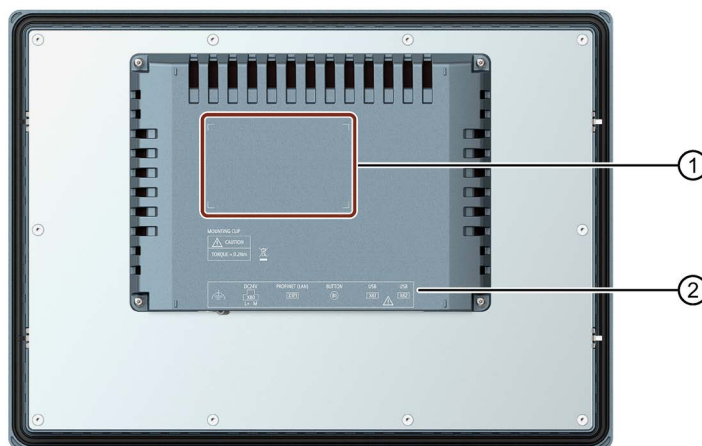

- ① Position of rating plate
- ② Interface labeling

1.4 Interfaces

The figure below shows the interfaces of the Unified Basic Panels using the MTP1200 Unified Basic as an example.

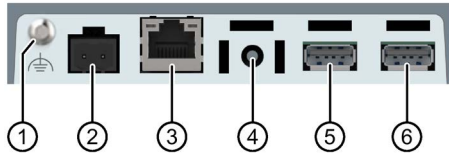

- ① Connector for functional ground
- ② X80 power supply connector
- ③ X1 PROFINET (LAN), 10/100/1000 Mbit
- ④ B1 button "Maintenance"
- ⑤ X61 USB
- ⑥ X62 USB

See also

Description of the interfaces (Page 134)

1.5 Accessories

An accessory kit with the necessary accessories is included with the HMI device.

Note

This section contains a selection of accessories that is suitable for your HMI device. You can find additional variants of this selection and the complete accessories portfolio in the Industry Mall on the Internet (<https://mall.industry.siemens.com/mall/en/WW/Catalog/Products/10144445>). Details such as the delivery quantity and technical specifications of accessories can be found in the Industry Mall under the respective article numbers.

You can find an overview of the status and compatibility of the accessories portfolio in the "Cross-list" on the Internet (<https://support.industry.siemens.com/cs/ww/en/view/40466415>).

HMI I/O components

Name	Article number
Plug for the power supply of the HMI device, 2-pin, screw technology	6AV6671-8XA00-0AX0
Plug for the power supply of the HMI device, 2x2-pin, spring-loaded terminal technology	6ES7193-4JB00-0AA0

Protective films

Name	Article number
4" front protective film	6AV2124-6DJ00-....
7" front protective film	6AV6881-0GJ22-....
10" front protective film	6AV6881-0KJ22-....
12" front protective film	6AV6881-0MJ22-....

"...." stands for the variant key of the article number.

Storage media

Use only the following storage media for the HMI device.

Name	Article number
SIMATIC HMI USB stick	6AV6881-0AS42-0AA1

Fasteners

Name	Article number
Set with plastic mounting clips	6AV6671-8XK00-0AX2

Input help

Name	Article number
Touch pen systems ELO and V2A	6AV6881-0AV2-....

"...." stands for the variant key of the article number.

Additional USB accessories

Additional USB accessories can be found on the Internet in the following entry:
FAQ 19188460 (<https://support.industry.siemens.com/cs/ww/en/view/19188460>)

Other accessories

You can find additional accessories for SIMATIC HMI devices on the Internet at the following link:

Accessories (<https://mall.industry.siemens.com/mall/en/WW/Catalog/Products/10144445>)

1.6 The HMI device in the operating process

The HMI device is part of a technical process. The following two phases are key to the way the HMI device is integrated in the process:

- Configuration
- Process management

Configuration

During the configuration phase, you create the user interfaces for operating and monitoring of the technical process on a configuration PC with WinCC. Project design comprises:

- Creating project data
- Saving project data
- Testing project data
- Simulating project data

Transfer

After compiling the configuration, you download the project to the HMI device.

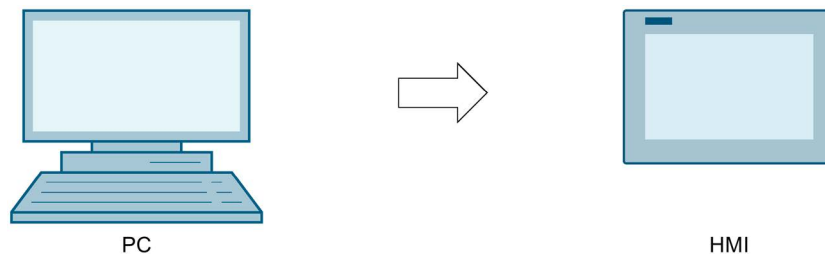

Process management

Process management is marked by two-way communication between HMI device and controller.

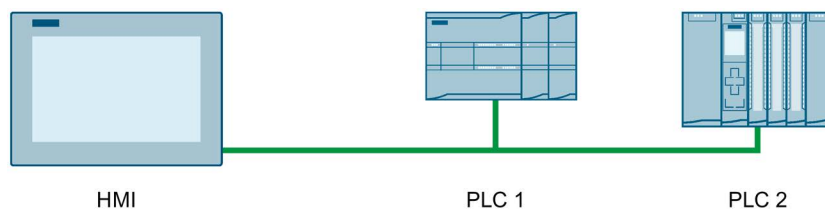

You then use the HMI device to operate and monitor the process.

Safety instructions

2.1 General safety instructions

The device is designed for operation in industrial areas for operating and monitoring of plant processes.

Observe the safety and accident prevention instructions applicable to your application in addition to the safety information given in the device documentation.

Open equipment

 WARNING
The device constitutes open equipment on the back side
The device constitutes open equipment on the back side. This means that you must integrate the device in an enclosure or cabinet where the device is operated via its front side. The enclosure or the cabinet must provide protection against electric shock and the spread of fire. The enclosure or the cabinet must meet the requirements for mechanical strength and the degree of protection for the relevant application.
Access to the enclosure or cabinet in which the device is installed should only be possible by means of a key or tool and only for qualified personnel.

 WARNING
Electrocution risk when control cabinet is open
When you open the control cabinet, there may be a dangerous voltage at certain areas or components.
Touching these areas or components can cause electrocution.
Disconnect the cabinet from the mains before opening it. Do not plug in or pull out plant components during operation.

Safety of the plant or the system

NOTICE
Safety is the responsibility of the assembler
The safety of any plant or system incorporating the equipment is the responsibility of the assembler of the plant or system.

ESD



An electrostatically sensitive device is equipped with electronic components. Due to their design, electronic components are sensitive to overvoltage and thus to the discharge of static electricity. Observe the corresponding regulations when handling ESD.

Industrial Security

Siemens provides products and solutions with industrial security functions that support the secure operation of plants, systems, machines and networks.

In order to protect plants, systems, machines and networks against cyber threats, it is necessary to implement – and continuously maintain – a holistic, state-of-the-art industrial security concept. Siemens' products and solutions constitute one element of such a concept.

Customers are responsible for preventing unauthorized access to their plants, systems, machines and networks. Such systems, machines and components should only be connected to an enterprise network or the internet if and to the extent such a connection is necessary and only when appropriate security measures (e.g. firewalls and/or network segmentation) are in place.

For additional information on industrial security measures that may be implemented, please visit (<https://www.siemens.com/industrialsecurity>).

Siemens' products and solutions undergo continuous development to make them more secure. Siemens strongly recommends that product updates are applied as soon as they are available and that the latest product versions are used. Use of product versions that are no longer supported, and failure to apply latest updates may increase customer's exposure to cyber threats.

To stay informed about product updates, subscribe to the Siemens Industrial Security RSS Feed under (<https://www.siemens.com/cert>).

Disclaimer for third-party software updates

This product includes third-party software. Siemens Aktiengesellschaft only provides a warranty for updates/patches for the third-party software if such updates/patches have been distributed as part of a Siemens software update service contract or officially released by Siemens Aktiengesellschaft. Otherwise, updates/patches are undertaken at your own risk. You can find more information about our Software Update Service offer on the Internet at Software Update Service (<https://support.industry.siemens.com/cs/ww/en/view/109759444>).

Notes on protecting administrator accounts

A user with administrator privileges has extensive access and manipulation options in the system.

Therefore, ensure there are adequate safeguards for protecting the administrator accounts to prevent unauthorized changes. To do this, use secure passwords and a standard user account for normal operation. Other measures, such as the use of security policies, should be applied as needed.

2.2 Security management for HMI devices

Data security

Data from external sources

The HMI device has external interfaces and can be connected to the Internet.

Data from untrusted sources represents a significant security risk.

Customers are responsible for transferring only data from trusted sources to the HMI device and only opening trusted files and web pages on the HMI device.

Entering passwords

If you enter passwords via an external keyboard, they can be logged and passed on unnoticed via a keylogger.

Use only the screen keyboard of the HMI device to input passwords.

Data backup to external data storage media

Data from the HMI device can be saved on USB storage media via the external interfaces.

Customers are responsible for protecting HMI device data stored on external storage media against unauthorized access. For example, use a suitable encryption or password protection for external storage media. Store the external storage media in a safe place.

Additional information

You can find additional information on security management of HMI devices on the Internet at the following address:

Panel Security Guidelines (<https://support.industry.siemens.com/cs/de/en/view/109481300>)

2.3 Data protection

Siemens observes the data protection guidelines, especially the requirements regarding data minimization (privacy by design). This means the following for this SIMATIC product: The product does not process / save any personal information, but only technical functional data (e.g. time stamps). If the user links this data to other data (e.g. shift plans) or if the user saves personal information on the same medium (e.g. hard disk) and therefore creates a personal reference in the process, the user has to ensure meeting the guidelines regarding data protection.

2.4 Notes about usage

NOTICE
The HMI device is approved for indoor use only.
The HMI device may be damaged if it is operated outdoors.
Operate the HMI device indoors only.

Note

Operate the device only in a normal atmospheric environment

The technical characteristics of the device described in the operating instructions are guaranteed if you operate the device in normal ambient air conditions with usual air composition.

Note

The device is intended for operation in a SELV/PELV circuit according to IEC/EN 61131-2 or IEC/EN/UL 61010-2-201 in a dry environment, i.e. dry environment at the rear of the device.

Additional information is available in the section "Operating conditions (Page 125)".

Industrial applications

The HMI device is designed for industrial applications. It conforms to the following standards:

- Requirements for interference emissions EN IEC 61000-6-4:2019
- Requirements for interference immunity EN IEC 61000-6-2:2019

Use in mixed-use zone

Under certain circumstances you can use the HMI device in a mixed-use zone. A mixed-use zone is used for housing and commercial operations that do not have a significant impact on residents.

When you use the HMI device in a mixed-use zone, you must ensure that the limits of the generic standard EN 61000-6-3 regarding emission of radio frequency interference are observed. Suitable measures for achieving these limits for use in a mixed-use zone include:

- Installation of the HMI device in grounded control cabinets
- Use of filters in electrical supply lines

Individual acceptance is required.

Use in residential areas

Note

HMI device not intended for use in residential area

The HMI device is not intended for use in residential areas. Operation of an HMI device in residential areas can have a negative influence on radio or TV reception.

Use with additional measures

The HMI device should not be used at the following locations unless additional measures are taken:

- In locations with a high degree of ionizing radiation
- In locations with severe operating conditions, for example, due to:
 - Corrosive vapors, gases, oils or chemicals
 - Strong electrical or magnetic fields of high intensity
- At locations that require special monitoring, e.g. in:
 - Elevators
 - Highly hazardous areas

TFT displays

NOTICE

Burn-in effect

A permanently displayed two-color or multi-color picture can cause a burn-in effect, i.e. the picture remains dimly visible for a certain period of time. The longer the image is burned in, the longer the image will last. In extreme cases, the image is permanently displayed.

The image outline usually disappears on its own when the screen remains switched off for some time. Screensavers that use active black when the backlight is on reduce the burn-in effect.

Note

Backlight

The brightness of the backlight decreases incrementally during operational life. You can extend the service life of the display and backlight by taking the following measures:

- Reduce the intensity of the backlight (Page 64).
- Observe the operating hours of the backlight, see section "Technical specifications (Page 130)".

Mounting and connecting the device

3.1 Preparing for installation

3.1.1 Checking the delivery

Check the package content for visible signs of transport damage and for completeness.

Note**Damaged parts**

A damaged part will cause the HMI device to malfunction.

Do not install parts damaged during shipment. In the case of damaged parts, contact your Siemens representative.

Check the scope of delivery of the HMI device, see section "Scope of delivery (Page 12)".

Additional documents may be included in the scope of delivery.

The documentation is part of the HMI device and is required for subsequent commissioning. Keep all enclosed documentation for the entire service life of the HMI device. You must pass along the enclosed documentation to any subsequent owner or user of the HMI device. Make sure that every supplement to the documentation that you receive is stored together with the operating instructions.

3.1.2 Checking the operating conditions

Observe the following aspects before installing the HMI device:

1. Familiarize yourself with the standards, approvals, EMC parameters and technical specifications for operation of the HMI device. This information is available in the following sections:
 - "Markings and approvals (Page 119)"
 - "Electromagnetic compatibility (Page 122)"
2. Check the mechanical and climatic ambient conditions for operation of the HMI device according to the following sections:
 - " Mechanical ambient conditions (Page 124)"
 - " Climatic ambient conditions (Page 124)"
3. Observe the notes on the local use of the HMI device in section "Notes about usage (Page 20)".
4. Observe the permissible rated current: +24 V DC

3.1.3 Permitted mounting positions

The HMI device is suitable for installation in:

- Mounting cabinets
- Control cabinets
- Switchboards
- Consoles

In the following, all of these mounting options are referred to by the general term "cabinet".

The device is self-ventilated and approved for inclined mounting at angles up to $\pm 35^\circ$ from the vertical.

NOTICE
Damage due to overheating
An inclined installation reduces the convection by the HMI device and therefore the maximum permitted ambient temperature for operation.
If there is sufficient convection from forced ventilation, the HMI device can also be operated in the inclined mounting position up to the maximum permitted ambient temperature for vertical mounting. The HMI device may otherwise be damaged and its certifications and warranty will be void.
The operating temperature ranges listed in this section apply to the rear and the front of the HMI device.

For detailed information regarding the permitted ambient temperatures, refer to section "Climatic ambient conditions (Page 124)".

Mounting position

Select one of the permitted mounting positions for your HMI device. The permitted mounting positions and the associated operating temperatures are described in the following sections using the MTP1200 Unified Basic HMI device as an example.

Mounting in landscape format

All Unified Basic HMI devices are suitable for mounting in landscape format.

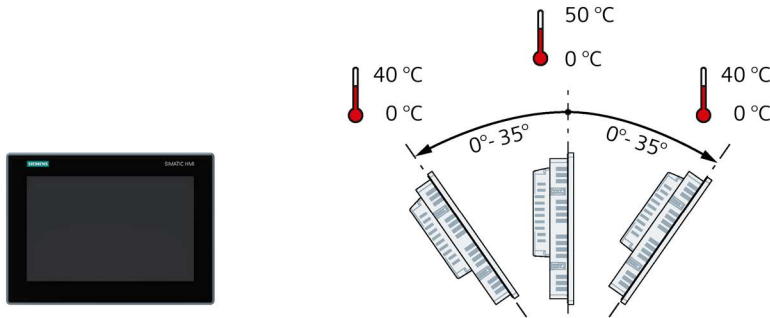

Mounting in portrait format

All Unified Basic HMI devices are suitable for mounting in portrait format. Select the appropriate screen format during configuration.

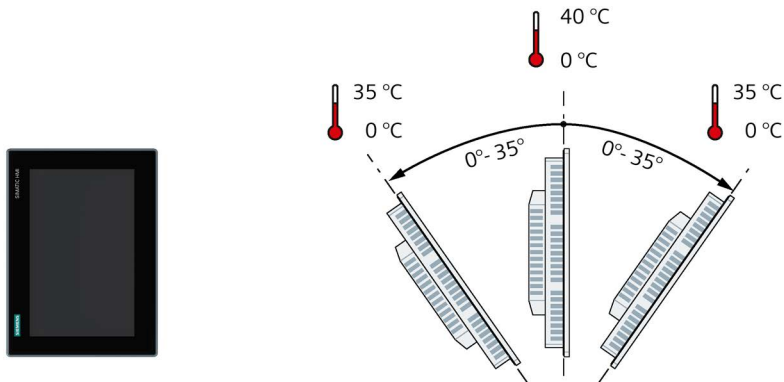

See also

Climate diagram (Page 125)

3.1.4 Checking clearances

The following clearances are required around the HMI device to ensure sufficient self-ventilation:

- At least 15 mm to both the right and left of the mounting cutout (in x direction) to allow for insertion of the mounting clips during installation
- At least 50 mm above and 50 mm below the mounting cutout (in the y direction) for ventilation
- At least 10 mm behind the rear panel of the HMI device (in the z direction)

The following figure shows the clearances for mounting the HMI devices in landscape format and portrait format using MTP1200 Unified Basic as an example:

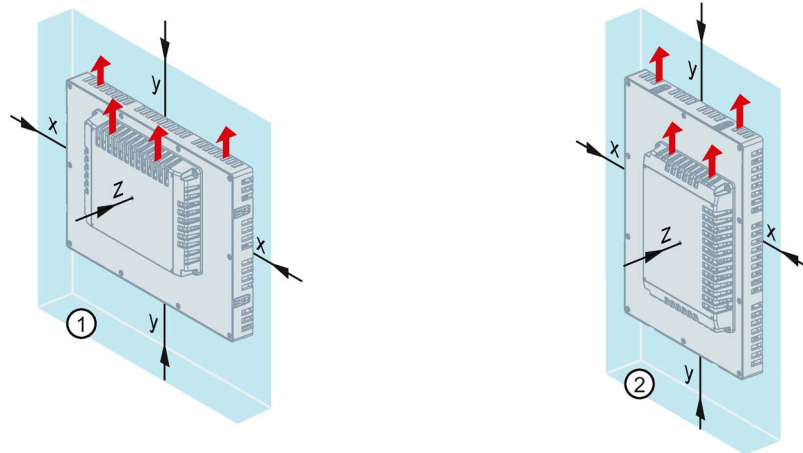

- ① Clearance for mounting in landscape format
- ② Clearance for mounting in portrait format
- x At least 15 mm distance
- y At least 50 mm distance
- z At least 10 mm distance

Note

Ensure that the maximum ambient temperature is not exceeded when mounting the device in a cabinet and especially in a closed enclosure.

3.1.5 Preparing the mounting cutout

Note

Stability of the mounting cutout

The material in the area of the mounting cutout must provide sufficient strength to guarantee lasting and safe mounting of the HMI device.

To achieve the degrees of protection described below, it must be ensured that deformation of the material cannot occur due to the force of the mounting clips or operation of the device.

Degrees of protection and installation area

The degrees of protection of the HMI device can only be guaranteed if the following requirements are met:

- Material thickness at the mounting cutout for degree of protection IP65 or Type 4X/12 (indoor use only, front face only): 2 mm to 6 mm
- Permissible deviation from plane at the mounting cutout: ≤ 0.5 mm
This condition must also be fulfilled for the mounted HMI device.
- Permissible surface roughness in the area of the seal: ≤ 120 μm (R_z 120)
- The installation area is dry and free from contamination, such as dust or lubricant.

Compatibility of the mounting cutout to other HMI devices

The Unified Basic HMI devices are mounting-compatible with standard SIMATIC Industrial PCs, Industrial Flat Panels, and Industrial Thin Clients with identical display diagonals.

Note that although the dimensions for the mounting cutout are the same, the device depth of the Unified Basic HMI devices may differ from that of compatible devices.

The following installation compatibility also applies:

HMI device	Mounting cutout compatible with	
	Basic Panels 2nd Generation	Unified Comfort Panels
MTP400 Unified Basic	KTP400 Basic	-
MTP700 Unified Basic	KTP700 Basic, KTP700 Basic DP	MTP700 Unified Comfort
MTP1000 Unified Basic	-	MTP1000 Unified Comfort
MTP1200 Unified Basic	KTP1200 Basic, KTP1200 Basic DP	MTP1200 Unified Comfort

Dimensions of the mounting cutout

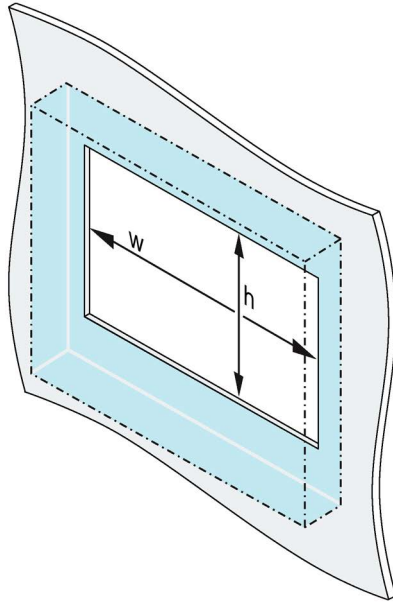

	w_0^{+1}	x	h_0^{+1}
MTP400	123	x	99 mm
MTP700	197	x	141 mm
MTP1000	264	x	189 mm
MTP1200	310	x	221 mm

Width and height should be reversed accordingly when mounting in portrait format.

3.2 Mounting the device

3.2.1 Notes on installation

Before installing the device, please ensure that the installation location complies with the following:

NOTICE

Use according to IEC 61010-2-201 requires an appropriate enclosure

The rear of the built-in device is classified as "Open Equipment" according to IEC 61010-2-201 for use in industrial control equipment.

For approval and operation according to IEC 61010-2-201, the device must be installed in an enclosure or integrated in a cabinet. The enclosure or the cabinet must provide protection against electric shock and the spread of fire. The enclosure or the cabinet must meet the requirements for mechanical strength and the degree of protection for the relevant application.

- Position the device so that it is not exposed to direct sunlight.
- Position the device so that it is easily accessible for the operator. Choose a suitable installation height.
- Ensure that the air vents of the device are not covered as a result of installation.
- Observe the permitted mounting positions (Page 23).

3.2 Mounting the device

3.2.2 Positions of the mounting clips

You fasten the built-in devices with the mounting clips from the accessory pack, which are also available as accessories (Page 14).

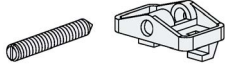

To achieve degree of protection IP65 on the front panel of the respective device, the mounting clips must be fitted at the positions shown below.

Device	Positions of the mounting clips
4" device	
7" device	
10" device	

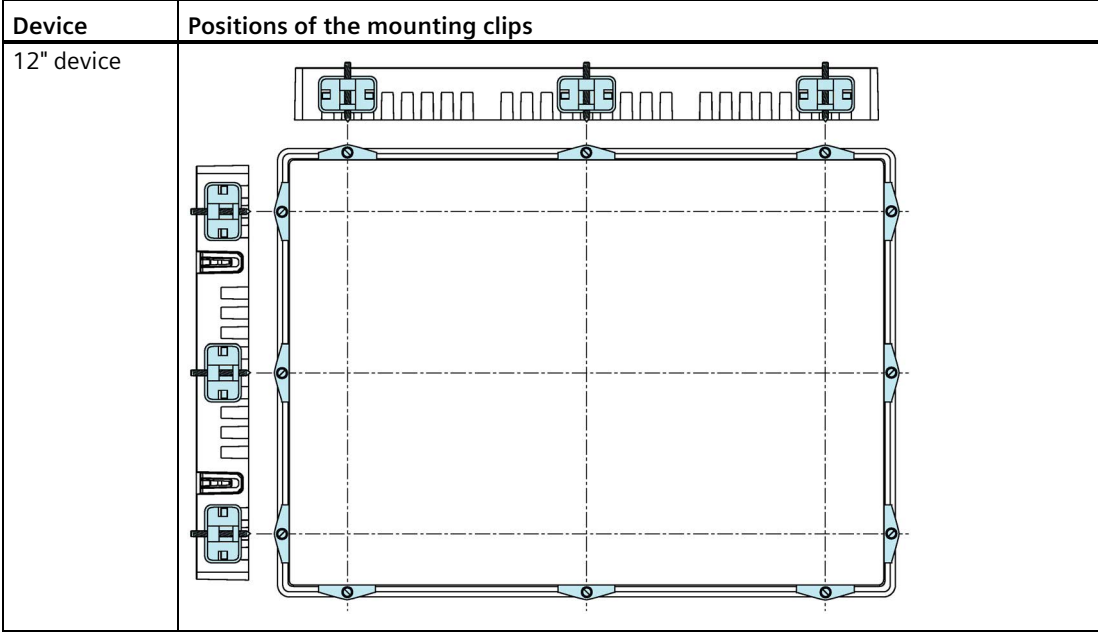

3.2.3 Fastening the built-in device with mounting clips

This section describes the installation of the Unified Basic HMI devices using the MTP1200 Unified Basic as an example.

Requirement

- All packaging components and protective films have been removed from the device.
- The following material and tools are available:
 - One torque screwdriver with slot insert, size 2
 - The mounting clips from the accessory kit

Screw the set screws into the mounting clips before mounting.



Procedure

Note

If the mounting seal is damaged, the degree of protection is not guaranteed.

1. Insert the device into the mounting cutout from the front.

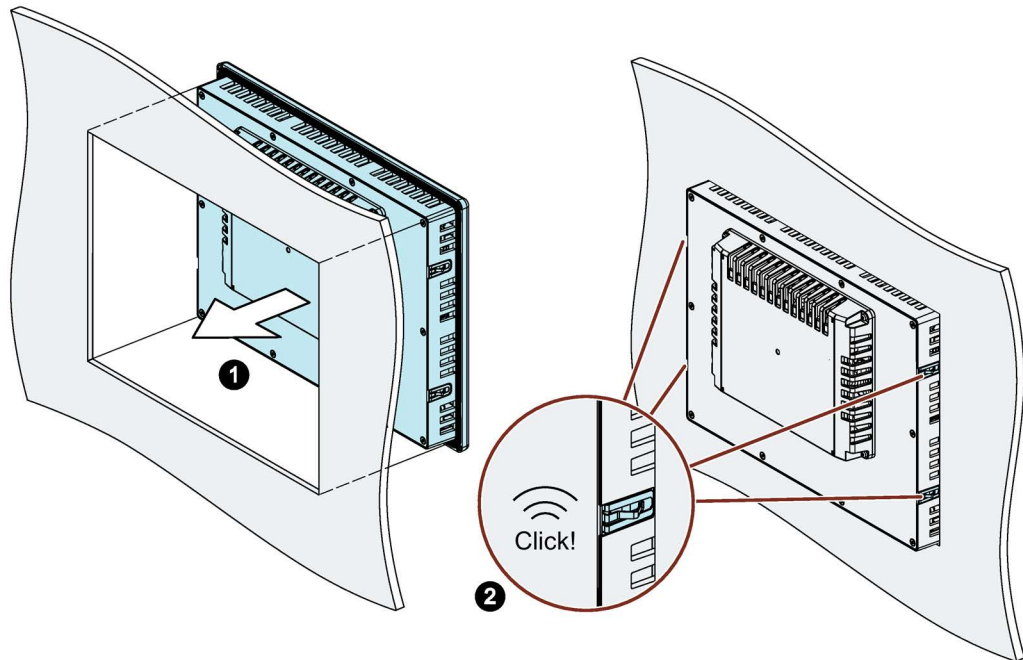

2. Make sure that the spring fasteners on the side of the device are fully engaged. If necessary, gently press the device into the recess if it is not fully engaged.
3. Insert a mounting clip into the cutout provided on the device. Make sure it is in the correct position; see the section "Positions of the mounting clips (Page 28)".

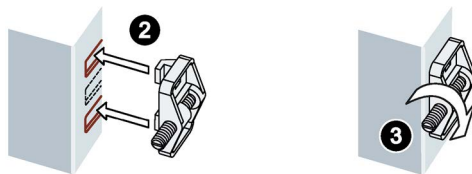

4. To secure the mounting clip, tighten the set screw with the screwdriver, torque 0.2 Nm.
5. Repeat step 3 and 4 for all mounting clamps until all clamps are fastened.
6. Check the fit of the mounting seal.

3.3 Connecting the device

3.3.1 Notes on connection

Requirement

- The HMI device must be mounted according to the specifications of these operating instructions.

Connection cables

Use only shielded standard cables as data connecting cables, order information is available on the Internet (<https://mall.industry.siemens.com>).

Note

Separate SELV/PELV circuits from other electric circuits or insulate the cables

The wiring of SELV/PELV circuits must either be separated from the wiring of other non-SELV/PELV electric circuits, or the insulation of all conductors must be rated for the higher voltage. Alternatively, a grounded shielding or additional insulation must be installed around the wiring for SELV/PELV circuits or the other electric circuits, based on IEC 60364-4-41.

Note for using the HMI device within the scope of UL approval:

 CAUTION
Use copper cables at connectors with terminal connections
Use copper (Cu) cables for all supply lines that are connected to the device with terminals, e.g. 24 V DC power supply cables to the 24 V DC power supply connectors.
Utiliser des câbles en cuivre sur les connexions à bornes
Utilisez des câbles en cuivre (Cu) pour tous les câbles d'alimentation qui sont raccordés à l'appareil par des bornes, par exemple les câbles d'alimentation 24 V CC sur le connecteur d'alimentation 24 V CC.

Connection sequence

NOTICE

Damage to the HMI device

If you do not keep to the connection sequence you could damage the HMI device.

It is crucial that you connect the HMI device in the following order:

1. Equipotential bonding
2. Power supply
Perform a power-up test to ensure the power supply is connected with the correct polarity.
3. Controller
4. Configuration PC, if required
5. I/O devices, if required

Disconnect the HMI device by completing the above steps in reverse order.

Connecting the cables

NOTICE

Observe local installation regulations

Observe the local installation regulations and the local installation conditions, such as protective wiring for power supply lines, when connecting the cables.

NOTICE

Thermal stability and insulation of the cables

Use cables with a maximum permissible operating temperature that is at least 20 °C higher than the maximum ambient temperature.

The insulation of the cables must be suitable for the operating voltage.

NOTICE

Short-circuit and overload protection

Different measures for short-circuit and overload protection are required when setting up an entire plant. The type of components and the level of obligation for the protective measures depends on the regulation that applies to your plant configuration.

- When connecting the cables, make sure that you do not bend the contact pins.
- Secure the cable connectors by fastening the connector to the socket with screws.
- Provide adequate strain relief for all connecting cables.
- The pin assignment of the ports is described in the technical specifications.

3.3.2 Equipotential bonding

Differences in electrical potential

Differences in electrical potential can develop between spatially separate plant components. Such electrical potential differences can lead to high equalizing currents across the data cables and therefore to the destruction of their interfaces. Equalizing currents can develop if the cable shielding is terminated at both ends and grounded to different plant components.

Differences in potential may develop when a system is connected to different mains supplies.

General requirements for equipotential bonding

Differences in potential must be reduced by means of equipotential bonding in order to ensure trouble-free operation of the relevant components of the electronic system. The following must therefore be observed when installing the equipotential bonding circuit:

- The effectiveness of equipotential bonding increases as the impedance of the equipotential bonding conductor decreases or as its cross-section increases.
- If two plant components are interconnected by means of shielded data cables and their shielding is bonded at both ends to the grounding/protective conductor, the impedance of the additionally installed equipotential bonding cable must not exceed 10% of the shielding impedance.
- The cross-section of an equipotential bonding conductor must be capable of handling the maximum equalizing current. Equipotential-bonding cables are required between two control cabinets with a minimum conductor cross-section of 16 mm².
- Use equipotential bonding conductors made of copper or galvanized steel. Establish a large surface contact between the equipotential bonding conductors and the grounding/protective conductor and protect them from corrosion.
- Clamp the shield of the data cable from the HMI device flush at the equipotential bonding rail using suitable cable clamps. The equipotential bonding rail should be as close to the HMI device as possible.
- Route the equipotential bonding conductor and data cables in parallel and with minimum clearance in between.

Note

Equipotential bonding cable

Cable shields are not suitable for equipotential bonding. Always use the prescribed equipotential bonding conductors for this. An equipotential bonding conductor between control cabinets must have a minimum cross-section of 16 mm². The cable between the ground bar and HMI device must have a minimum cross-section of 4 mm².

Wiring diagram

The following figure shows the connection of the functional grounding for equipotential bonding with MTP1200 Unified Basic as an example and similarly applies to the other Unified Basic HMI devices.

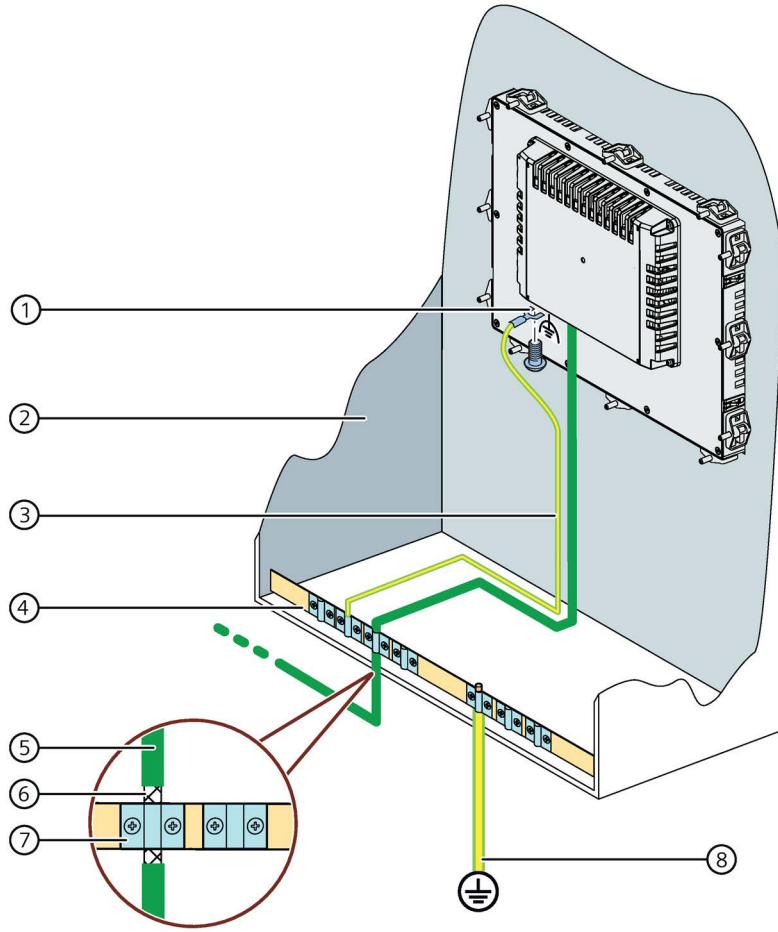

- ① Connection for functional ground; use a fork cable lug or ring cable lug, size M4
- ② Control cabinet
- ③ Equipotential bonding cable, 4 mm²
- ④ Equipotential busbar for equipotential-bonding cables, ground connection, and shield support of the data cables
- ⑤ PROFINET data cable
- ⑥ Shield of the PROFINET data cable, connected to the equipotential busbar
- ⑦ Cable clip
- ⑧ Ground connection, 16 mm²

3.3.3 Connecting the power supply

NOTICE
<p>Safe electrical isolation</p> <p>For the 24 V DC supply, only use power supply units with safe electrical isolation (SELV/PELV) according to IEC 61010-2-201.</p> <p>The supply voltage must be within the specified voltage range. Otherwise, malfunctions at the HMI device cannot be ruled out.</p> <p>The following applies for a non-isolated system design: Connect the GND 24 V connection from the 24 V power supply output to equipotential bonding for uniform reference potential. You should always select a central point of termination.</p>

Connection cables for the power supply connector

The power supply connector is included in the accessory pack.

Use flexible cables with wire end ferrule for the power supply connector that meet the specifications in the following table.

Cables for the 24 V DC power supply connector		Specification
Cable type		Flexible cable (Cu), with wire end ferrule
Connectable cable cross-sections		0.5 ... 1.5 mm ² AWG*: 20 ... 16
Number of cables per connection		1
Stripped length of the cables		7 ... 8 mm
Wire end ferrules according to DIN 46228	Without plastic sleeve	Form A, 7 mm long
	With plastic sleeve 0.5 ... 1.5 mm ²	Form A, 7 mm long
Tool		Screwdriver, conical, 3 ... 3.5 mm
Connection technology		Screw-type terminal
Tightening torque		0.5 ... 0.6 Nm

* American Wire Gauge

More information on the supplied power supply connectors and additional permitted power supply connectors can be found in the section "Accessories (Page 14)".

Connecting the power supply connector

NOTICE

Do not damage the socket

Do not tighten the screws of the power supply connector when it is plugged into the HMI device. The pressure from the screwdriver could damage the HMI device socket.

Connect the power supply cables when the power supply connector is unplugged from the HMI device.

1. Turn off the power supply of the HMI device.
2. Connect the power supply cables to the power supply connector as shown in the following figure.

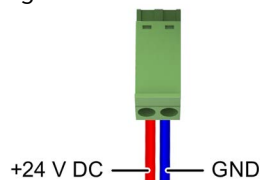

3. Connect the power supply connector to the corresponding socket of the HMI device as shown in the example in the figure below.

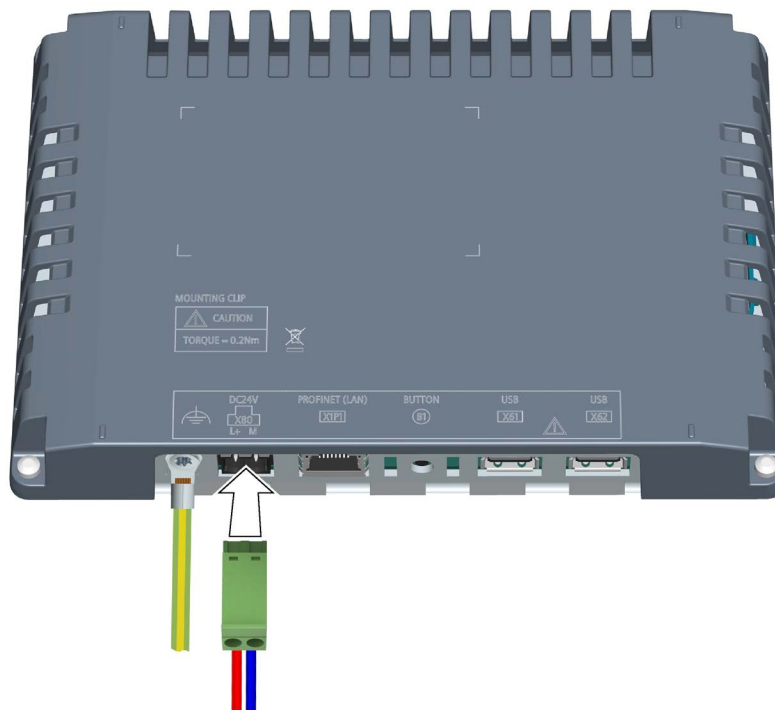

4. Verify the correct polarity of the cables using the interface labeling on the back of the HMI device.

Reverse polarity protection

The HMI device comes with electronic reverse polarity protection which prevents the device from being damaged in case the power supply cables are connected incorrectly.

3.3.4 Connecting the configuration PC

Wiring diagram

The following figure shows how to connect the HMI device to a configuration PC using MTP1200 Unified Basic as an example.

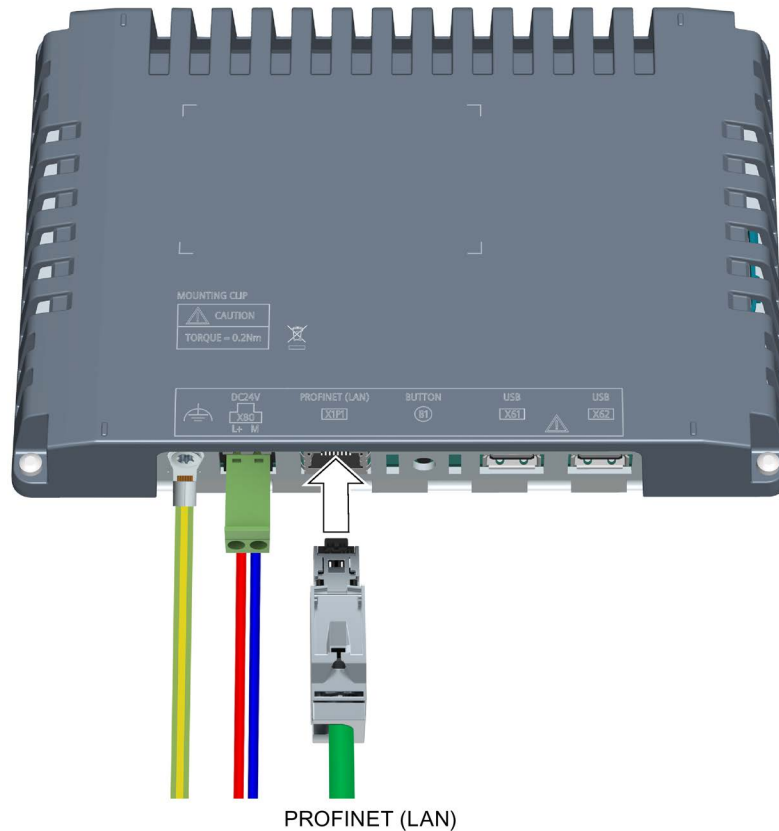

Procedure

Proceed as follows:

1. Switch off the HMI device.
2. Switch on the configuration PC.
3. Connect the HMI device to the configuration PC via the X1 interface.
4. Switch on the HMI device.

Result

The configuration PC and HMI device are connected. To enable communication, assign an IP address to the HMI device.

Note

Updating the operating system

If there is no serviceable HMI device image on the HMI device, you can only update the operating system by restoring the factory settings via the PROFINET (LAN) interface.

3.3.5 Connecting the controller

Wiring diagram

The figure below shows how to connect the HMI device to a controller using MTP1200 Unified Basic as an example.

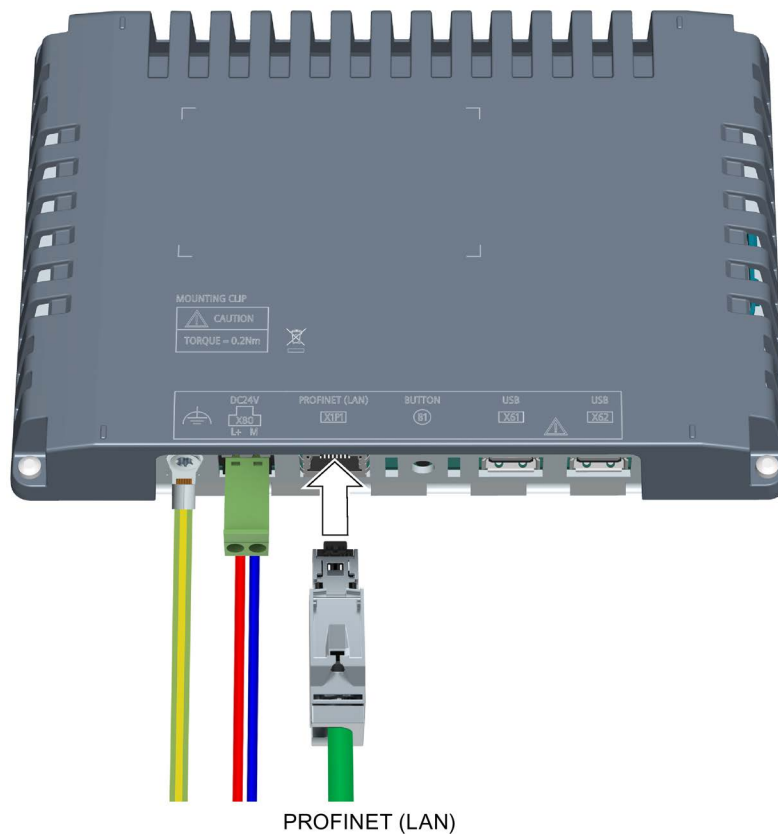

Use the PROFINET (LAN) X1 interface for process coupling. You can find more information on compatible controllers in the section "Communication with controllers (Page 135)".

Note

Use approved cables only

If you do not use approved cables to connect a SIMATIC S7 controller, you may experience malfunctions.

Use only approved cables to connect a SIMATIC S7 controller.

Note

Use only straight connectors

Use only straight cables whenever possible to connect a controller. Bent connectors can cover adjacent interfaces.

Standard cables are available for the connection. You can find order information in the Industry Mall (<https://mall.industry.siemens.com>).

PROFINET

Note

Observe the instructions regarding the installation of PROFINET networks, in the "PROFINET System Description (<https://support.industry.siemens.com/cs/ww/en/view/19292127>)" manual.

The X1 interface supports PROFINET basic services.

3.3.6 Connecting a USB device

Below are examples of industrial grade devices you can connect to the USB type A interfaces of the HMI device:

- External mouse
- External keyboard
- USB stick
- Industrial USB Hub 4, article number 6AV6671-3AH00-0AX0
- Mobile handheld readers ("barcode scanners"):
 - SIMATIC MV320, article number 6GF3320-OHT01
 - SIMATIC MV340, article number 6GF3340-OHT01

Note

USB cable length maximum 1.5 m

USB cables with lengths of more than 1.5 m do not ensure secure data transfer.

The cable may not be longer than 1.5 m.

Note

Functional problem with the USB interface

If you connect a USB device with its own power supply to the USB port, make sure that the USB ground terminal of the external device is connected to ground.

Note

Excessive rated load of the USB interface

A USB device with too high a power load may possibly cause functional problems.

Observe the values for the maximum load rating of the USB interface, see section "Technical specifications (Page 130)".

Note

Potential loss of data

If the HMI device accesses its data when a USB storage medium is removed, the data on the storage medium cannot be fully read or written, or it may even be destroyed.

If your process requires you to change the USB storage medium during operation, you need to take this into account by employing suitable mechanisms in the configuration.

Do not remove the USB storage medium during operation while data is being accessed.

Formatting of USB sticks

The following file systems are supported for USB sticks:

- NTFS
- FAT32

We recommend using the "NTFS" formatting method which offers greater data consistency and flexibility regarding the size of the saved files.

Wiring diagram

The following figure shows how to connect a USB device using the MTP1200 Unified Basic as an example.

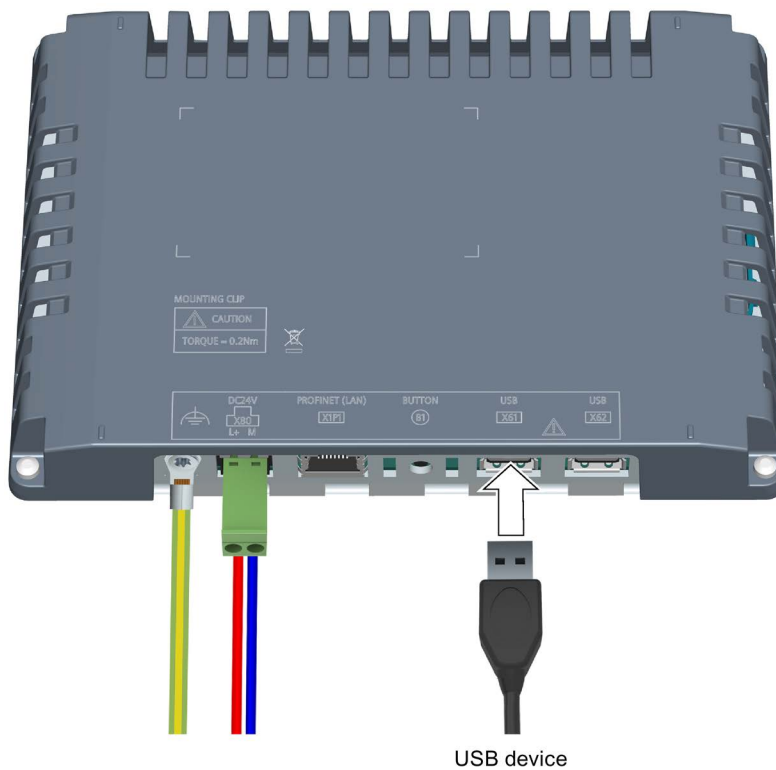

3.3.7 Switching on, testing and switching off the device

Switch on the HMI device

1. Switch on the power supply. The display lights up.

If the HMI device fails to start after a longer period, you may have crossed the cables on the power supply connector. Check the connected cables and correct the polarity if necessary.

If a project is available on the HMI device, then the project is started after the defined delay time.

If there is no project on the HMI device, the Control Panel is displayed.

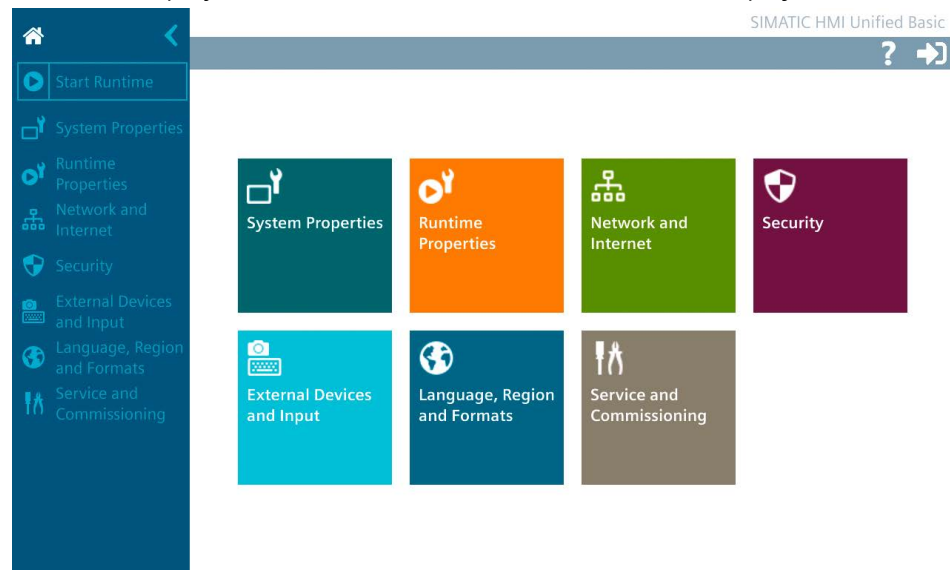

2. If desired, operate the project or configure the HMI device via the Control Panel. If you no longer need the HMI device, switch it off.

Switching off the HMI device

1. Close the project on the HMI device.
2. Switch off the power supply.

3.3.8 Securing the cables

After the power-up test, secure the connected cables with a strain relief.

Use the supplied plastic strain relief element.

The following figures show how to install the plastic strain relief elements using the MTP1200 Unified Basic as an example.

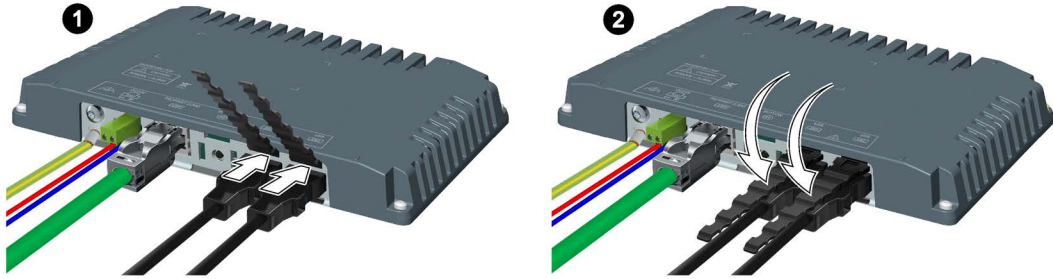

Next, use cable ties to secure the cables to the marked fastening points.

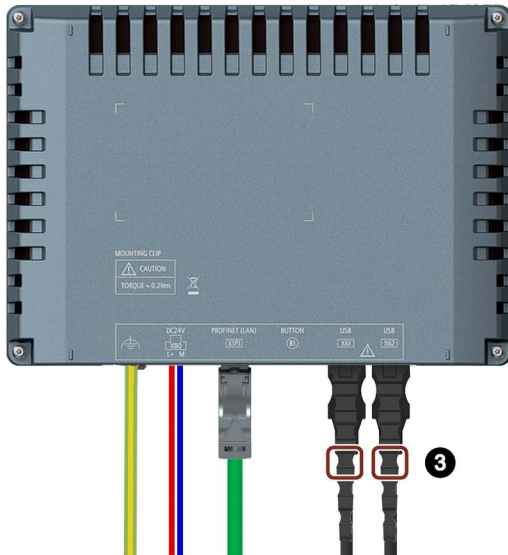

3.4 Removing the device

The HMI device is generally removed in the reverse order used for installing and connecting.

Procedure

Proceed as follows:

1. If a project is running on the HMI device, close the project with the HMI device configured for this purpose. Wait until the Control Panel is displayed.
2. Switch off power to the HMI device.
3. Remove all cable ties on the HMI device used for strain relief of the connection cables.
4. Remove all plug-in connectors and the equipotential bonding cable from the HMI device.
5. Secure the HMI device so that it cannot fall out of the mounting cutout.
6. Loosen the screws of the mounting clips and remove all mounting clips.
7. Take the HMI device out of the mounting cutout.

See also

Connecting the device (Page 31)

Fastening the built-in device with mounting clips (Page 29)

Operating the device

4.1 Operator input options

Depending on the connected peripheral devices, the following operator input options are available:

- Capacitive multi-touch screen
- Screen keyboard
- External keyboard, connected via USB
- External mouse, connected via USB

If you need an external keyboard or mouse during operation, then use industrial grade devices. Devices that are not industrial grade are approved only for the commissioning.

As an alternative, you can also operate or monitor the device via remote access using a browser, see section "Web access to the HMI device (Page 54)".

4.2 Important notes on touch screen

You operate the capacitive multi-touch screen with one finger or with two-finger gestures.



WARNING

Personal injury or property damage due to no earth connection

An inadequate ground connection or the lack of one will cause malfunction of the capacitive multi-touch screen. Functions may not work properly. This can result in personal injury or property damage.

- Always connect the HMI device to a ground conductor.
- The ground conductor from the HMI device must be connected directly to ground with low impedance (short connection, minimum conductor cross-section 4 mm²).

You can find additional information on connecting the earth conductor in the section "Equipotential bonding (Page 33)".

! WARNING**Personal injury or property damage due to maloperation**

Incorrect operation cannot be ruled out for devices with touch screens. This can result in personal injury or property damage.

Take the following precautions:

- Configure the plant so that safety-related functions are not operated with the touch screen.
- Only carry out an operator action if a plant screen is shown on the HMI device screen.
- Switch off the HMI device for cleaning and maintenance.

NOTICE**Damage to the touch screen**

The following operation significantly reduces the service life of the touch screen and can lead to total failure:

- Touching with pointed or sharp objects
- Shock contact with hard objects.

Only touch the touch screen with a finger or a touch pen.

! WARNING**Danger of malfunctions due to incorrect execution of gestures on the touch screen**

If gestures are executed incorrectly on the touch screen with multi-touch function, these gestures may not be recognized or could be recognized incorrectly. The entries made are then not implemented by the HMI device at all, are implemented incorrectly, or in an unintended manner.

Incorrect execution of multi-touch functions can lead to errors in the operation of the plant and thus to physical injury.

Observe when operating the capacitive multi-touch screen:

- The touch screen reacts to contact on its surface, not to pressure.
- When using a touch pen: Operate the touch screen only with a touch pen for capacitive touch.
- Avoid unintended multiple touches, for example, with your knuckles.

Before using the HMI device, familiarize yourself with the supported multi-touch functions of the operating system and the applications. Ensure that the gestures which the user executes on the multi-touch screen are recognized by the application. It is possible that certain gestures need to be trained beforehand.

Notes on operation

Note

Do not touch the capacitive multi-touch screen during startup

The HMI device automatically calibrates the capacitive multi-touch screen during startup. The touch screen is locked during calibration.

Do **not** touch the touch screen during startup. Make sure that you do **not** rest on the touch screen with the palm of your hand during startup.

Make sure that there are **no** conductive liquids on the touch screen during startup.

Note when operating the capacitive multi-touch screen:

- Surface contact with a diameter of about 5 to 20 mm is required for an operator action to be detected.
- An operation with gloves with a material thickness of < 2 mm is detected in most cases. However, check the usefulness of the gloves you are using.
- To avoid incorrect operation, certain inputs are ignored and blocked from further entry:
 - Simultaneous operation with more than 5 fingers.
 - Surface contact with a diameter of > 3 cm, for example, resting the palm of the hand on the touch screen
 - As soon as the touch screen is no longer touched, input is possible again.

Functions of the capacitive multi-touch screen

General functions

- Detection of up to 5 finger touches at a time.
- Recognition of the gestures supported by the operating system and the runtime software.
- You do not need to calibrate the capacitive multi-touch screen.

Security functions in an industrial environment

The capacitive multi-touch screen is locked for security reasons when the following disturbances occur:



- There is a conductive liquid on the touch screen with ground contact via the enclosure or the operator, for example.
- An electromagnetic disturbance that exceeds the specification in the technical data of the device exerts an influence, see section "Electromagnetic compatibility (Page 122)".

Once the interference is over, the capacitive multi-touch screen is no longer locked.

4.3 Supported gestures

4.3.1 Supported gestures in the Control Panel

The following touch gestures are available in the Control Panel.

Icon	Gesture	Behavior
	Tap	<ul style="list-style-type: none"> Opens an entry in the navigation area of the Control Panel To activate an input object (such as input box, option button, drop-down list), tap on the input object.
	Vertical dragging with one finger	To scroll vertically in the window pane or in lists, drag vertically in the corresponding area with one finger.
	Horizontal dragging with one finger	<ul style="list-style-type: none"> Opens an entry in the navigation area of the Control Panel To scroll horizontally in the window pane or in lists or to set a slider, drag horizontally in the corresponding area with one finger.

4.3.2 Supported gestures in the runtime project

Various touch gestures are available for the runtime operation. Some touch gestures have different effects in plant screens than in operating elements.

Note



No operation with three or more fingers.

Use only one or two fingers when operating with touch gestures.





If you use more than two fingers with touch gestures, this can cause incorrect operation.

In the case of multitouch operation with several fingers, you only operate the respectively configured objects.

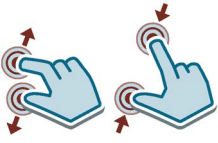

Touch gestures supported in plant screens

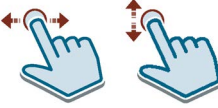



Icon	Gesture	Function
	Tap	To select an object, tap on the corresponding location in the plant screen.
	Drag with one finger	To move objects with a window, drag the object in the desired direction using its title bar.

4.3 Supported gestures

Icon	Gesture	Function
	Zooming	To zoom in or out of a display, drag it with two fingers to an area in which there are no operating elements.
	Drag with two fingers	To move the zoomed area of a plant screen, drag it with two fingers to an area in which no operating elements are located.
	Swipe	To switch between plant screens, swipe horizontally or vertically with one finger. A touch area must be configured for this function.
	Keep pressed	The function corresponds to a right-click. To trigger the event configured for the right-click, press the object or link for more than one second.

Touch gestures supported in operating elements

Icon	Gesture	Behavior	Supported WinCC operating elements
	Tap	<ul style="list-style-type: none"> To select a row, tap the row. With corresponding configuration of the operating element: To select a cell. With corresponding configuration of the operating element: For sorting a column. To sort a column, tap on the column title. In trend controls: Enlarges the curve zone along the X/Y axis. Requirement: The button "Zoom +/-", "Zoom Time axis +/-" or "Zoom Value axis +/-" is pressed. 	<ul style="list-style-type: none"> Alarm control Process control Trend control Ruler window System diagnostics control Parameter set control
	Tapping with two fingers	<p>Zooms out of the trend control. Requirements: The button "Zoom +/-", "Zoom Time axis +/-" or "Zoom Value axis +/-" is pressed. Leave some space between the fingers while tapping.</p>	<ul style="list-style-type: none"> Trend control

Icon	Gesture	Behavior	Supported WinCC operating elements
	Drag with two fingers	To move window contents, such as zoomed tables or trends, drag the window of the operating element with two fingers.	<ul style="list-style-type: none"> Trend control Process control Ruler window Browser
	Vertical swiping	Vertical scrolling using list entries	<ul style="list-style-type: none"> Drop-down list box
	Drag with one finger	<ul style="list-style-type: none"> Moves the ruler. Moves the x-axis or the y-axis <p>Requirement: The button "Move curve zone" or "Move axis zone" is pressed or the operating element is enlarged.</p>	<ul style="list-style-type: none"> Trend control
		<ul style="list-style-type: none"> To select multiple rows. Tap a row and drag your finger upward or downward. With corresponding configuration of the operating element: For selecting several lines. 	<ul style="list-style-type: none"> Process control Ruler window System diagnostics control Parameter set control
		To adjust the column width, tap on the grid line of a column and drag your finger to the left or right.	<ul style="list-style-type: none"> Alarm control Ruler window
		To move zoomed window contents, drag them with one finger.	<ul style="list-style-type: none"> Browser Screen window
	Zooming	To zoom in or out of a display in an operating element, drag the window of the operating element with two fingers.	<ul style="list-style-type: none"> Trend control Browser Screen window
	Two-hand operation Hold the enable button with one finger and operate an object with the second finger.	<p>An operating element can be configured for two-hand operation, which means the object can only be operated when an enable button is pressed at the same time.</p> <p>For two-hand operation in WinCC, configure:</p> <ul style="list-style-type: none"> A button that is defined as an enable button in the security properties of a plant screen. The "Explicit enable required" security property for all operating elements that should only be operable when the enable button is pressed. 	

4.4 Using the screen keyboard

4.4.1 The screen keyboards

When you touch an operating element in Runtime or in the Control Panel on the touch screen of the HMI device that requires input, the screen keyboard is displayed.

The alphanumeric screen keyboard

The key layout of the screen keyboard is based on the layout of a PC keyboard in the corresponding language. The figures below show the different levels of the screen keyboard using the English layout ("QWERTY") as an example.

Lowercase letter level



The <SHIFT> button is used to switch to uppercase level.

Use the <&123> button to switch to the special character level.

Use the <Polyline> button to switch to the graphic input level.

Uppercase letter level



The <SHIFT> button is used to switch to lowercase level.

Use the <&123> button to switch to the special character level.

Use the <Polyline> button to switch to the graphic input level.

Special character level 1



Use the <1/2> button to switch to special character level 2.

Use the <ABC> button to switch to the last used letter level.

Special character level 2



Use the <2/2> button to switch to special character level 1.

Use the <ABC> button to switch to the last used letter level.

Graphic input level



The graphic input level is only available in conjunction with the "British English" language setting.

In the graphic input level you can draw numbers or letters in a large touch area. The drawn numbers or letters are recognized and transferred to the active input box.

The <ABC> button is used to switch to the input of letters in the touch area.

The <123> button is used to switch to the input of numbers in the touch area.

The <Aa> button to switch to the last used letter level.

Numerical screen keyboard

If a numeric value is to be entered in a input box, the numerical screen keyboard is displayed.

Numeric screen keyboard in the Control Panel



Numerical screen keyboard in Runtime



Checking numerical value limits

Tags can be assigned limit values. Any entry of a value outside this limit is rejected. If an alarm view is configured, a system alarm is triggered and the original value is displayed again.















Decimal places of numerical values

The configuration engineer can define the number of decimal places for a numerical text box. The number of decimal places is checked when you enter a value in this field.

- Decimal places that exceed the limit are ignored.
- Unused decimal places are padded with "0" entries.

4.4.2 Control keys on the screen keyboard

The following control keys are available on the screen keyboard:

	Switch to lowercase level		Switch to special character level 1 in a letter level
	Switch to uppercase level		Switch to special character level 2 in special character level 1.
	Toggle language		Switch to special character level 1 in special character level 2.
	Delete character left of cursor		Switch to the last letter level used in a special character level Switch to letter input in the graphic input level
	Switch to graphic input level		Switch to numeric input in the graphic input level
	Switch to the last used letter level in the graphic input level.		Close screen keyboard, confirm input
	Creates a "smiley" in the active input box		Confirm entry, close the screen keyboard
	Creates three points in the active input box		

4.5 Commissioning the HMI device

Requirement

The HMI device is mounted and connected according to these operating instructions.

Procedure

The following procedure describes how to typically include the HMI device during operation.

1. Configure the HMI device in WinCC. When configuring, consider your security concept in the security settings. Configure a user administration. Define a user with the "Control Panel access" function right who can protect the HMI device against unauthorized access to the Control Panel.
2. Make sure that the network address of the HMI device corresponds to the configured network address.
3. Transfer your project including user administration via WinCC from the configuration PC to the HMI device.

4.6 Web access to the HMI device

4. If necessary, have the Control Panel protected against unauthorized access by an HMI device administrator under "Security" > "Control panel access".
5. Check the authorizations of the operators in the Control Panel under "Security" > "User management" and adjust the settings if necessary.
6. If necessary, deactivate one or more interfaces for storage media under "External Devices and Input" > "Hardware interfaces".
7. Check date and time under "Language, Region and Formats" > "Date and time".
8. Set the required delay time for the start of the project under "Runtime Properties" > "Automatic runtime start".

Result

Commissioning has been completed, the HMI device is ready to use. Depending on your application, further individual settings may be required in addition to the steps described.

4.6 Web access to the HMI device

As an alternative to direct operation on the device, you can access the following applications of the HMI device via a browser:

- The runtime project
- The user management

The number of supported connections via Web client is 1.

Requirement

- The device on which the browser is running is connected to the HMI device in the same subnet.
- The browser used supports HTML5 and accepts self-signed certificates.
- The following applies depending on the application you want to access:
 - "WinCC Unified RT": Web access to the runtime project is activated, see section "Web client (Page 72)". The runtime software has been started.
 - "User Management": The settings for the user management were loaded to the HMI device, see sections "User management (Page 79)" and "UMAC settings (Page 88)".

Opening applications via the homepage

The HMI device has a convenient homepage for applications with web access.

To open the homepage, enter the following URL in the browser: "**https://<ip>**"

Use the IP address of the HMI device instead of the placeholder "<ip>".

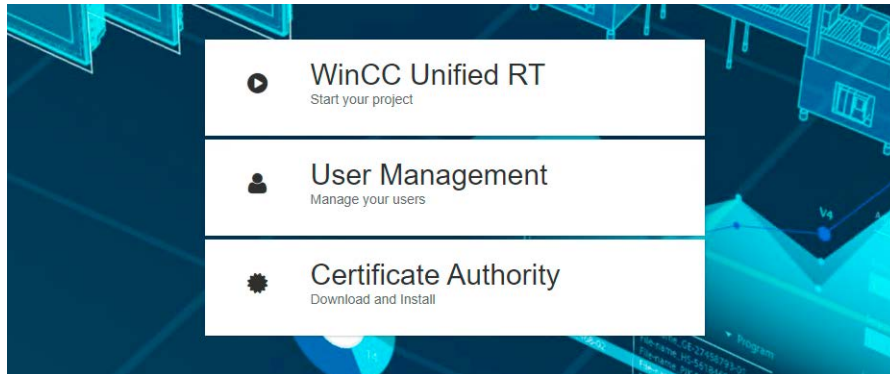

- "WinCC Unified RT": Button for opening the "Sign in" dialog for runtime.
- "User Management": Button for opening the "Sign in" dialog for the user management. You can find detailed information on web-based user management via a browser in the TIA Portal Help under "Visualizing processes (RT Unified) > Configuring users and roles (RT Unified) > Using the user management on the Unified Comfort Panel > Managing local users > Managing local users in runtime".
- "Certificate Authority": Button for downloading the HMI device certificate for a secure connection.

Opening applications without the homepage

Use the following URLs to open the "Sign in" dialog in the respective application without the homepage.

- "WinCC Unified RT": "**https://<ip>/device/WebRH**", note the uppercase/lowercase spelling.
- "User Management": "**https://<ip>/umc**"

Use the IP address of the HMI device instead of the placeholder "<ip>". When you use a browser that runs directly on the HMI device, you can also use "localhost" instead of the IP address.

Installing a certificate

The following applies when you open an application with web access for the first time via a browser: To set up a secure connection between browser and application, you must download the certificate of the application and install it in your browser as "trusted".

NOTICE

Use CA certificates generated via the WinCC Unified Certificate Manager

If you use a self-signed certificate from a non-trustworthy source, the data transfer is not protected from attacks.

For web access to the HMI device, use CA-certificates that were generated via the WinCC Unified Certificate Manager. To do so, proceed as follows:

1. Generate a CA certificate with the WinCC Unified Certificate Manager .
2. Copy the CA certificate to a USB flash drive.
3. Import the CA certificate in the Control Panel via "Security">"Certificates" as "Trusted Certificate Authority".
4. Install the certificate in your browser as described in the following sections.

Download certificate

You have the following options to download the certificate:

- Using the "Certificate Authority" button on the homepage.
- By clicking on the icon or the "Not secure" message in the address bar of the browser.

Installing the certificate as "trusted" in the "Web Browser"

Follow the instructions in the browser documentation to import the application certificate and classify it as "trusted".

A secure connection to the website is now established with the trusted certificate.

Note

Certificate is valid for all applications with web access

For a secure connection to the applications with web access, the HMI device certificate must only be downloaded once and classified as "trusted".

Sign in using the "Sign in" dialog

You use the "Sign in" dialog to sign in to an application with web access.

"Sign in dialog" for runtime-related applications

The following figure shows the "Sign in" dialog for the following applications.

- "WinCC Unified RT"
- "User Management"

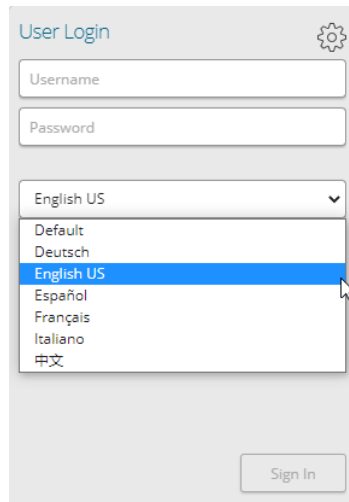

Procedure:

1. Select the required runtime language.
2. Enter the user name and password.
3. Click "Sign in".

If the selected language is not available in the runtime project, the default language is used.

Notes on web access

After signing in, read the following notes on web access in the various applications:

"WinCC Unified RT"

After successful login, a user session is active. Note the following for user sessions:

- A maximum of one user session is permitted on one HMI device.
- User management is used in a user session when signing in. Changes to the user management of the HMI device have no effect on the session in progress.
- You have the following options to completely close a user session:
 - Configure an operating element with the system function "Log off".
 - Close all instances, that is, all open browser windows.

You can find more information on remote access via "Web client" in the TIA Portal Help under: "Visualizing processes (RT Unified) > Configuring remote access > Web client".

"User Management"

- The user list is only visible and editable for users who have been assigned the "User Management" function right.
- You can find detailed information on web-based access to the user management in the TIA Portal Help under "Visualizing processes (RT Unified) > Configuring users and roles (RT Unified) > Using the user management on the Unified Comfort Panel > Managing local users > Managing local users in runtime".

4.7 Notes on operation

Storage media

Note

Storage media displayed multiple times

The operating system of the HMI device supports multiple mount points. This means that USB storage media may be displayed multiple times in file browser dialogs. This does not affect the functionality of the HMI device.

Note

Directory for storage media in Runtime and in apps

You will find the storage media under "/media" in file browser dialogs of the Runtime software.

Note

Exporting Runtime data

Use a USB storage medium for exporting Runtime data such as the data from a alarm control or trend control.

If several USB storage media are connected to the HMI device, the storage medium at interface X61 is used for the export.

Operating the Control Panel

5.1 Opening the settings

The Control Panel can be opened as follows:

- After switching on the device, if there is no project on the HMI device.
- Via an appropriately configured operating element in your project.
- By terminating the project running on the HMI device.

The following figure shows the open main window of the Control Panel:

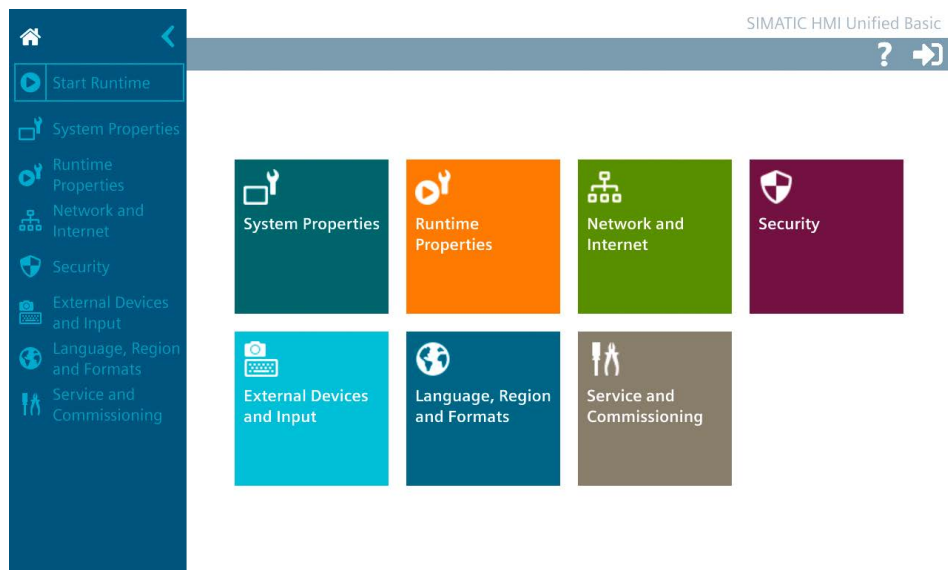

To make the corresponding settings, select an entry in the navigation area or a tile in the window pane.

Note

Enabling password protection for the Control Panel

The password protection for the Control Panel is deactivated when the HMI device is delivered, which means that all users can make changes in the Control Panel.

To protect your HMI device against unauthorized changes, you can activate password protection for the Control Panel, see section "Control panel access (Page 87)".

NOTICE
Do not change settings during configuration PC communication
If you change settings in the Control Panel while the HMI device is being addressed by the configuration PC, a malfunction may occur.
Do not change the settings when the HMI device is being addressed by the configuration PC, for example during project download or via the "Flash LED" function.

Logging on in the Control Panel

The "Login" button is located on the right of Control Panel title bar.



If user management has been configured for the HMI device and transferred to the HMI device, you can log in using the "Login" button. After logging in, you have the authorizations that were defined for your login in the configuration. To access all functions in the Control Panel, a user needs the "Control Panel access" function right.

Note

Number of login attempts

The number of attempts for the correct entry of the login credentials can be configured in WinCC under "Runtime settings > Security".

If the login credentials are entered incorrectly one more time, the user involved will be locked. The user must be deleted and recreated, or you must reload the User Management into the HMI device.

Ensure you enter the login credentials correctly.

After you have logged in, the "Logout" button is displayed in the title bar instead of the "Login" button.



Switching the navigation area

You can switch the navigation area from the maximized display to the minimized display as follows.

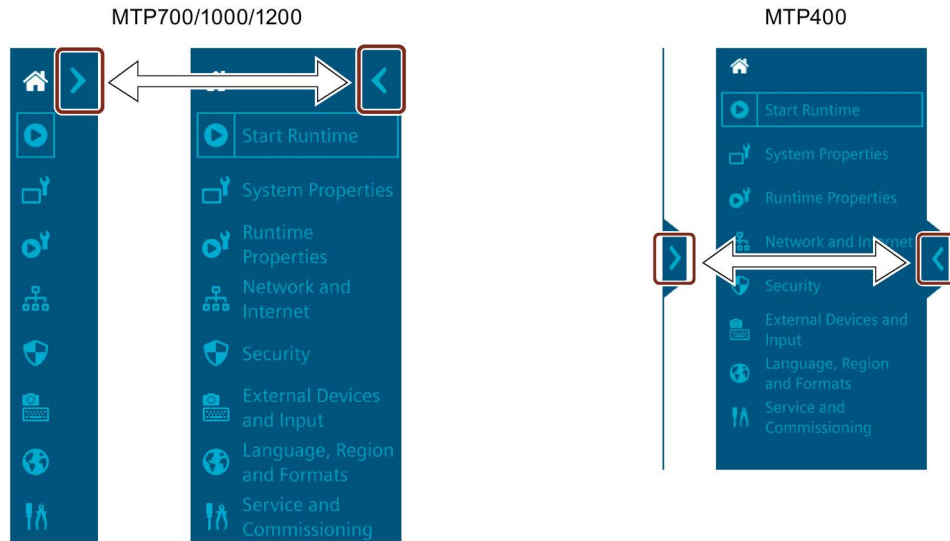

Control Panel help

In the title bar, you will find the "Help" button to the left of the "Login" button.



Open the "SIOS" dialog using the "Help" button.











In the "SIOS" dialog, you have the following options to open the Control Panel help:

- Scan the QR Code or enter the link below the QR Code in the browser of an external device with Internet connection.
The help opens on the external device. You can read the help on the external device and navigate in the Control Panel of the HMI device at the same time.
- If your HMI device has an Internet connection, click on the link below the QR Code.
The help opens on the HMI device.

5.2 Overview of functions

The table below shows the icons of the Control Panel and provides links to the corresponding function descriptions in the appropriate sections.

Icon	Name	Assigned functions
	-	Open the main window of the Control Panel
	Start Runtime	Start project on the HMI device See also "Automatic runtime start (Page 70)"
	System Properties	Panel information (Page 63) Display (Page 64) Screensaver (Page 65) Update OS (Page 66) Reboot (Page 68) Performance (Page 69)
	Runtime Properties	Project information (Page 70) Automatic runtime start (Page 70) Alarm persistency (Page 71) Web client (Page 72) Load project from storage (Page 73)
	Network and Internet	Network settings (Page 76)
	Security	User management (Page 79) Certificates (Page 83) Control panel access (Page 87) UMAC settings (Page 88)
	External Devices and Input	Hardware interfaces (Page 90) Connected devices (Page 91)
	Language, Region and Formats	Date and time (Page 92)
	Service and Commissioning	Transfer (Page 94) Update OS (Page 66) Backup (Page 97) Restore (Page 98) Trace options (Page 100)

Some settings, such as interface parameters, runtime settings, or settings for user management, can be configured in WinCC and loaded to the HMI device. After loading, you can adjust the settings as needed in the Control Panel of the HMI device.

5.3 System Properties

5.3.1 Panel information

Under "Panel information" you will find information specific to your HMI device, which you will need, for example, if you contact Technical Support.

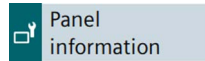

Properties

The following figure shows an example. Variable display values are shown with the wildcard character "#" or between angle brackets "<>".

Device type:	MTP1200 Unified Basic
Article number:	6AV2 123-3MB32-0AW0
Serial number:	CRV-257169
Firmware/Image version:	V19.00.00.0#_0#.0#.0#.##
Runtime version:	19.0.0.#
Bootloader version:	R0#.0#.00.00_01.01.01.0#
Bootloader release date:	<dd>/<mm>/<yyyy>
PN-X1 MAC address:	00-0e-8c-25-71-67

- "Device type": HMI device type designation
- "Article number": Article number of the HMI device
- "Serial number": HMI device serial number
- "Firmware/Image version": Version of the firmware and operating system.
- "Runtime version": Version of the runtime software located on the HMI device
- "Bootloader version": Version of the bootloader
- "Bootloader release date": Bootloader release date
- "PN-X1 MAC address": MAC address of the HMI device interface X1

5.3.2 Display

Under "Display" you define the display orientation and the display brightness via the intensity of the backlight.



NOTICE
Backlight reduction
The brightness of the backlight decreases with increasing service life. To avoid shortening the service life of the backlight unnecessarily, reduce the backlight.

Orientation

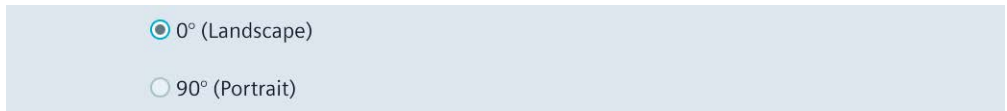

- "0° (Landscape)" (default setting): Select this option for HMI devices that have been installed and configured in landscape format.
- "90° (Portrait)": Select this option for HMI devices that have been installed and configured in portrait format.

Note

Display orientation and Runtime project

The display orientation in the Control Panel should match the display orientation of the HMI device in the WinCC configuration. Before switching the orientation in the Control Panel, adjust the configuration and reload the project into the HMI device.

The display orientation in the Control Panel should only be switched if no runtime project is running on the HMI device.

The HMI device must be restarted if you switch the display orientation in the Control Panel.

Brightness

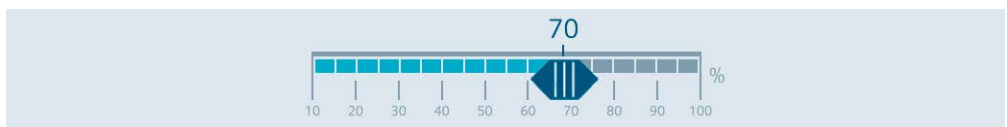

Set the desired display brightness using the slider.
Value range: 10 to 100%. Default setting: 70%

The display brightness can also be set within the value range via the configuration.

5.3.3 Screensaver

Under "Screensaver" you define the time until the automatic activation of the screensaver and the brightness of the backlight when the screensaver is active.

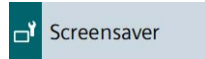

NOTICE

Activating the screensaver

If an image is displayed on the screen for long time, its outline may remain dimly visible on the display.

This effect is reversible when you use a screensaver.

General Settings

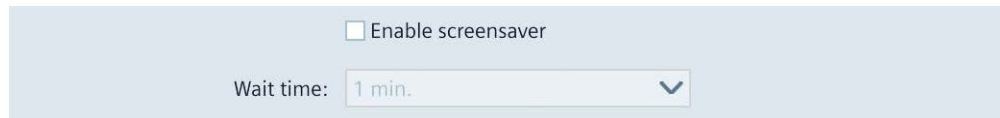

- "Enable screensaver": Select this option to activate the screensaver. Default setting: "deactivated".
- "Wait time": Time to activate the screensaver, value range 1 to 120 minutes. Default setting is "1 min."

The screensaver is automatically activated if the HMI device is not operated within the specified period of time.

Brightness of screensaver

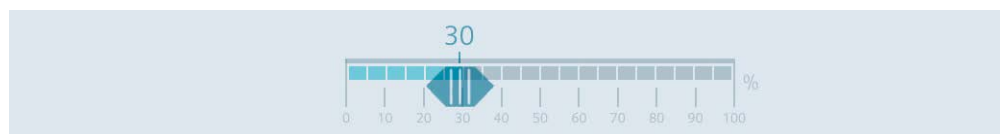

Use the slider to set the desired display brightness of the screensaver, value range 0 to 100%. Default setting is "30 %".

To deactivate the screensaver, tap the touch screen briefly. For safety reasons, this touch is not evaluated as an operator action. Therefore, no unintentional functions can be triggered.

The screen saver is also deactivated when the HMI device is accessed remotely, for example, via the configuration PC.

5.3.4 Update OS

The firmware and operating system version of the HMI device must be compatible with the firmware and operating system version of the installed WinCC software. If this is not the case, then you must update the operating system.

Use "Update OS" to update the operating system of the HMI device. The operating system is contained in several firmware files. The master file has the extension ".fwf". The number of additional files varies; these files have the file name of the master file and a sequential number (".0", ".1", ".2", etc.) as an extension.

The "Update OS" function is available under both "System Properties" and "Service and Commissioning".

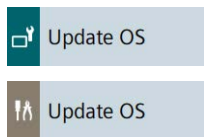

NOTICE

Updating the operating system deletes data on the HMI device

Project, parameter sets and user administration will be deleted when you update the operating system on the HMI device.

Before updating the operating system, backup the data on the HMI device, if necessary.

All settings, except the following settings which you changed in the Control Panel before updating the operating system, are retained even after the update of the operating system:

- The external interfaces become activated again (default setting), see section "Hardware interfaces (Page 90)".
- The time zone is reset to the default setting "(UTC) Coordinated Universal Time", see section "Date and time (Page 92)".

Use an industrial USB flash drive to load the firmware.

Firmware files for the HMI devices can be downloaded from the Internet (<https://support.industry.siemens.com/cs/ww/en/view/109746530>). Observe the documentation included with the download.

Note

Do not rename firmware files

If you change the name of the firmware files, the operating system can no longer be updated with these firmware files. The firmware files become unusable. Leave the name of the firmware files unchanged.

Note

Copy firmware files completely

If you copy the firmware files, be sure to also copy the master file ".fwf" together with all associated firmware files (".0", ".1", ".2", etc.).

If one of the files is missing, the operating system cannot be loaded.

Alternatively to the "Update OS" function in the Control Panel, you can use the "Update OS" function in WinCC.

Panel Information

Device type:

Image version:

- "Device type": HMI device type designation.
- "Image version": Version of the firmware and operating system.

Select storage media for OS update

Use the selection list to select the storage medium on which the firmware file is located.

Firmware files on external storage

Name	Path	Image Version
UBP_4_12_V19_0.fwf	/media/simatic/data-s...	V19.00.00.01_00.01...
UBP_4_12_V19_0.fwf	/media/simatic/data-s...	V19.00.00.01_00.01...
UBP_4_12_V19_0.fwf	/media/simatic/data-s...	V19.00.00.01_00.01...

- The list shows all firmware files that can be loaded into the HMI device. Select the desired firmware master file (.fwf) from the list.
- "Update OS": Button for starting the loading process.
The HMI device restarts after the "Update OS" button is pressed. The loading process then begins.
A dialog with a progress bar is displayed on the HMI device for each firmware file.
The HMI device is restarted again after the completion of the loading process.
The main window of the Control Panel is displayed after the restart. The operating system on the HMI device is updated.

5.3.5 Reboot

You can restart the HMI device manually under "Reboot". The restart can be carried out normally or in maintenance mode.

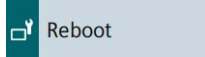

In the following cases the HMI device is automatically restarted after confirmation:

- You have made changes under "Network settings", see section "Network settings (Page 76)".
- You have switched screen orientation under the "Orientation" option, see section "Display (Page 64)".
- You have switched the "Enable alarm persistency" option, see section "Alarm persistency (Page 71)".

A manual restart of the HMI device is required in the following case:

- You have changed the interface parameters under "Media redundancy" in the configuration and loaded the project to the HMI device again.

NOTICE
Data loss All volatile data is lost with a restart. Make sure that no project is running on the HMI device and no data is being written to the flash memory.

Reboot panel



"Reboot panel": Button for a simple restart of the HMI device ("soft reboot").

Reboot in maintenance mode

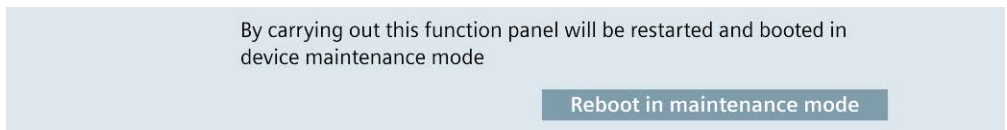

"Reboot in maintenance mode": Button for a restart in maintenance mode. The restart in maintenance mode is required to reset the HMI device to factory settings.

The HMI device restarts after the "Reboot in maintenance mode" button is pressed. The "Maintenance Mode" dialog box is displayed for a period of 10 minutes. In this period you can connect the HMI device to a configuration PC and reset the HMI device to factory settings with the ProSave software.

See also

Resetting an HMI device to factory settings via ProSave (Page 113)

5.3.6 Performance

Under "Performance" you can activate the monitoring of the internal flash memory.

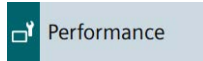

Flash Memory Monitoring Section

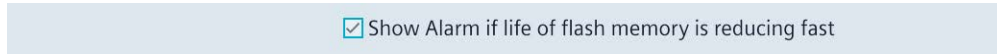

"Show Alarm if life of flash memory is reducing fast": Option to activate flash memory monitoring. The default setting is "activated".

If the option is activated, the state of the flash memory is checked cyclically. If the cyclical check results in a high load on the flash memory, the message "Flash memory life time reducing fast" is displayed regularly.

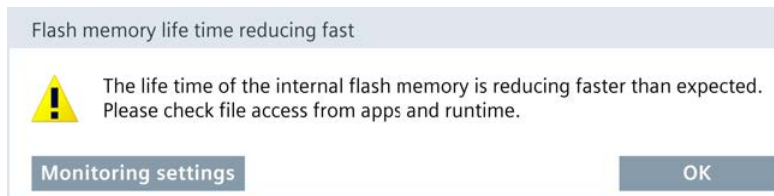

- "Monitoring settings": Button for opening the "Performance" settings in the Control Panel. Press the button, note the cause specified under "Source" and contact the corresponding administrator or configuring engineer.
- "OK": Button for acknowledging the alarm.

Last alarm

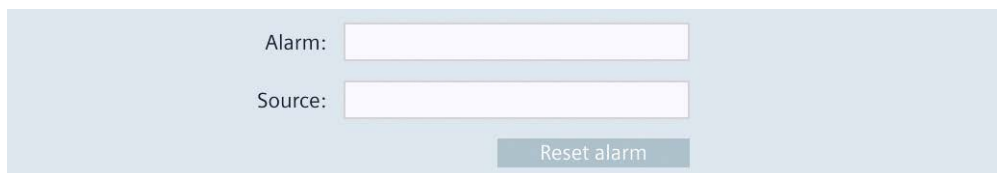

- "Alarm": Display panel with the last alarm that was displayed about the status of the flash memory.
- "Source": Display field with information on the cause of the last alarm. Pass this information on to the administrator or project engineer, who can change the settings in the corresponding app or the configuration of the HMI device so that the "Flash memory life time reducing fast" alarm no longer appears.
- "Reset alarm": Button for deactivating the regularly occurring "Flash memory life time reducing fast" alarm. The button can only be operated by users with the "Control Panel Administrator" authorization. After pressing the button, the "Flash memory life time reducing fast" alarm is only displayed again when the next cyclic check results in a high load on the flash memory.

5.4 Runtime Properties

5.4.1 Project information

Under "Project information" you can view the project-specific information that uniquely identify the project on the HMI device.

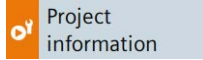

Project information

Name:	Line 1 Station 1
Device name:	HMI_RT_1
Project ID:	06c084b8-2b5b-2cc5-59df-c477d9b4d23a

- "Name": Name of the project is equivalent to the name of the project in WinCC (TIA Portal).
- "Device name": Automatically generated name of the runtime project on the HMI device.
- "Project ID": Unique identification of the runtime project is equivalent to the "Runtime ID" of the project in WinCC (TIA Portal).

5.4.2 Automatic runtime start

Under "Automatic runtime start" you define whether the project on the HMI device starts automatically or not after a defined delay time.

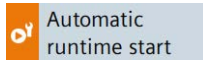

Automatic runtime start

Waiting time(s):	no automatic runtime start
	0
	15
	30
	45
	60
	no automatic runtime start

"Waiting time(s)": Drop-down list for determining whether the project on the HMI device starts automatically after a specified delay time or not.

Selection options:

- "0": The project is started directly after the operating system.
- "15" to "60": The project starts after a delay time of 15 to 60 seconds. During the delay time, the dialog "Runtime Start" is displayed with a countdown and the following buttons:
 - "Cancel": The dialog is closed, Runtime does not start.
 - "Skip": The delay time is skipped, Runtime is started.
- "no automatic runtime start" (default setting): The project is not started automatically, but via the "Start Runtime" button in the Control Panel.

Starting Runtime

While Runtime starts on the HMI device, the dialog box "Runtime Start" is displayed with an initialization message. The Control Panel cannot be operated while Runtime is starting.

Note

To open the Control Panel from Runtime, configure an operating element to which the "ShowControlPanel" or "StopRuntime" system function is assigned.

5.4.3 Alarm persistency

You can enable or disable deactivate the retentivity of the alarm buffer under "Alarm persistency". The default setting is "deactivated".

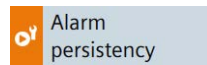

Note

Back up data before deactivating the retentivity

When you deactivate the retentivity of the alarm buffer and still need the data in the alarm buffer, back up this data before deactivating the retentivity in a log.

Alarm persistency configuration



- "Storage media": Selection list for defining the storage medium for the retentive alarm buffer. Selection options:
 - "Internal Memory": Alarms are written to the internal flash memory.
- "Enable alarm persistency": Option to enable or disable the retentivity of the alarm buffer. The default setting is "deactivated".

When the retentivity of the alarm buffer is activated, the retentive alarm data is backed up every two seconds to the selected storage medium. With a high number of alarms, the storage medium is subject to an equally high number of read and write cycles.

If the retentivity of the alarm buffer is deactivated, the alarm buffer is emptied and the retentive alarm data is no longer backed up to the selected storage medium. This means the storage medium is used less with a high number of alarms.

Switching the "Enable alarm persistency" option requires a restart, and the "Enable alarm persistency" dialog is displayed. Restart the system using the "OK" button.

5.4.4 Web client

Under "Web client", you can enable web-based client access to the runtime project. Operator control in runtime via a client is asynchronous, that is, the display content of the server does not change while the client is operating in runtime.

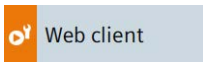

Web client configuration



- "Enable web access to runtime": Option to enable web access to the runtime project.

Web access to the runtime project

When web access is enabled, you can access the runtime project via a browser, see section "Web access to the HMI device (Page 54)".

You can find more information on remote access via "Web client" in the TIA Portal Help under: "Visualizing processes (RT Unified) > Using distributed systems > Web client".

5.4.5 Load project from storage

Under "Load project from storage", you can load into the HMI device a project that was backed up on an external storage medium in WinCC (TIA Portal).

You generate the necessary project data in WinCC by configuring the HMI device and then using drag-and-drop to move the folder of the HMI device (e.g. "HMI_1 [<DeviceType>]") to an external storage medium (📁 icon) under "Card Reader/USB memory".

Recommendation: The Runtime and firmware versions of the project should match those of the HMI device.

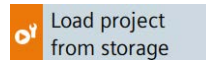

Select storage media for project transfer

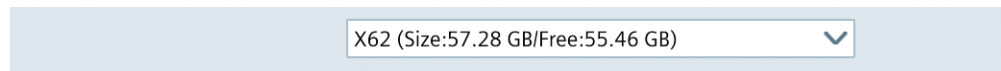

Select the storage medium on which the backed-up project is stored.

Projects on external storage

Project Name	Device Type	RT Version
HMI_RT_1[Line 1 Station 1]...	MTP1200 Unified Basic	19.0.0.0
HMI_RT_1[Line 1 Station 2]...	MTP1200 Unified Basic	19.0.0.0
HMI_RT_1[Line 1 Station 1]...	MTP1200 Unified Basic	19.0.0.1

- The list includes all projects that are located on the external storage medium.
- "Show details": Button for displaying additional information on a selected project.
- "Load project": Button for loading the selected project.

Displaying details and checking compatibility

If you have selected a project you can use the "Show details" button to display more information about the selected project and check whether the project can be loaded into the HMI device.

The screenshot shows a 'Project details' dialog box with the following fields and values:

Name:	Line 1 Station 1
Device:	HML_RT_1
RT Version:	19.0.0.0
Project path:	/media/simatic/X62/Simatic.HMI/RT_Projects/HML_RT_1[Line 1 Station 1] - Full 2023-11-22 - 11.11.11.zip
Project ID:	fc874e1a-aaf1-492d-7e1d-01e9883052ae
Date created:	22/11/2023 11:11:11
Size:	4419 Kbs
Compatibility:	Compatible

A 'Close' button is located at the bottom right of the dialog box.

- "Name": Name of the project.
- "Device": Name of the HMI device in the project.
- "RT Version": Runtime version of the project.
- "Project path": Path of the project on the external storage medium.
- "Project ID": Unique identification of the runtime project is equivalent to the "Runtime ID" of the project in WinCC (TIA Portal).
- "Date created": Date on which the project in WinCC (TIA Portal) was saved to a storage medium.
- "Size": Size of the project on the storage medium.
- "Compatibility": A message about the compatibility of the project and the HMI device is displayed in this output field. Depending on the degree of compatibility, the message is highlighted in color.

The following messages can be displayed in the "Compatibility" output field:

- The message "Compatible": Project and HMI device are compatible, the project can be loaded without any problem.
- Messages of the "Warning" type highlighted in orange: Firmware and/or runtime version of project and HMI device differ. The versions are compatible, an "Upgrade" or "Downgrade" is optional. The project can be loaded.
- Messages of the "Error" type highlighted in red: The project cannot be loaded for one of the following reasons.
 - Project and device type are incompatible, i.e. the project was created for a different device type. To load the project, replace the device in WinCC.
 - Firmware and/or Runtime version of project and HMI device are incompatible, an "Upgrade" or "Downgrade" is required. To load the project, update the operating system of the HMI device.

You can find information on updating the operating system at the end of this section and under "See also".

Load project

The "Load preview" dialog is displayed via the "Load project" button.

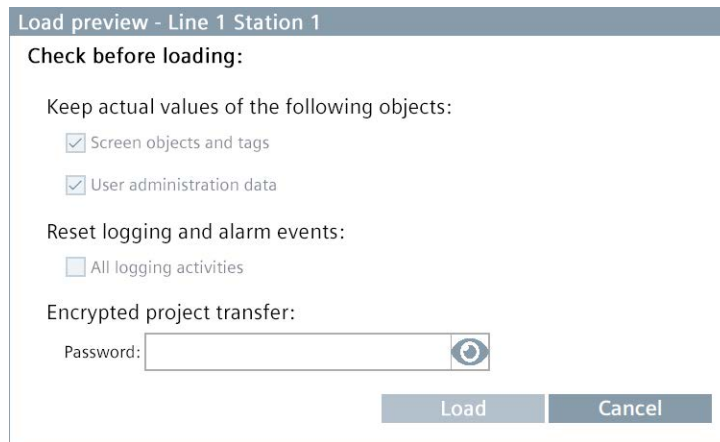

- Under "Keep actual values of the following objects", you specify whether the process values of the following objects are to be retained:
 - "Screen objects and tags": Option for keeping the process values of screen objects and tags on the HMI device.
 - "User administration data": Option for keeping the user management on the HMI device.

Under "Reset logging and alarm events", you specify whether data in logs and alarm events are to be deleted:

- "All logging activities": Option for deleting all logs and alarm events.

The "Encrypted project transfer" area is displayed when encrypted transfer is enabled for the selected project. In this case, enter the password that was set in WinCC for the encrypted transfer.

- The "Load" button loads the project into the HMI device, taking the selected settings into account.
After the loading process, you can start the project via the "Start Runtime" function on the HMI device.

Activation of the options that are currently grayed out is envisaged in a later firmware version.

See also

Update OS (Page 95)

Updating the operating system (Page 111)

5.5 Network and Internet

5.5.1 Network settings

Under "Network settings", you can change settings for the interface X1, which supports PROFINET basic services.

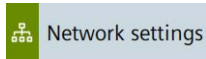

The interface name is displayed above the settings.



The settings under "Network settings" are retained after a restart or update of the operating system.

In the following cases, the settings under "Network settings" are not retained:

- If the HMI device is reset to factory settings, all settings will be reset to their default values.
- When a project with changed network settings is loaded to the HMI device, the values from the project are applied.

PROFINET

Device name:	<input type="text" value="mtp1200.x1"/>
Converted name:	<input type="text" value="mtp1200.x1"/>
MAC address:	<input type="text" value="00-0e-8c-25-71-67"/>

- "Device name": PROFINET name of the interface. It may not contain any spaces and must be unique in the local network.
- "Converted name": Display field with the PROFINET name of the interface. It contains the entry under "Device name", automatically converted according to PROFINET naming conventions.
- "MAC address": Display field with the MAC address of the X1 interface of the HMI device.

IP address

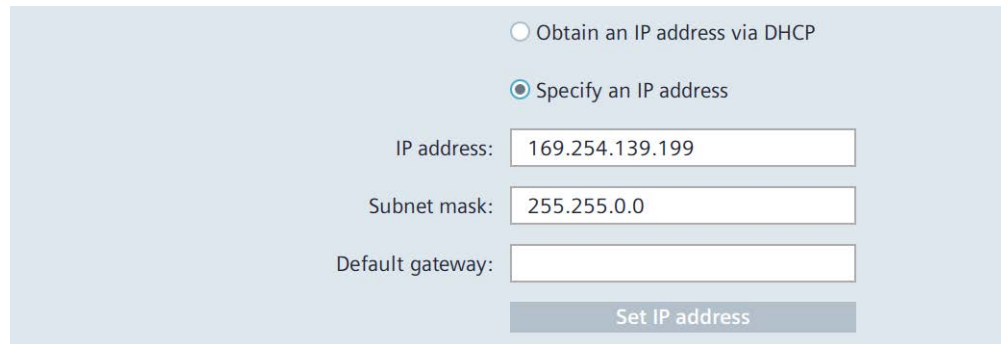

Obtain an IP address via DHCP

Specify an IP address

IP address:

Subnet mask:

Default gateway:

- "Obtain an IP address via DHCP" (default setting): Option to automatically assign the IP address via the DHCP server.
- "Specify an IP address": Option to manually assign the IP address.
- "IP address": IP address of the X1 interface. The IP address must be unique in the local network.
- "Subnet mask": Subnet mask for the IP address of the X1 interface.
- "Default gateway": IP address of the gateway (router) if several different local networks are used.
- "Set IP address": Button for saving the specified IP address parameters.

Note

If you select the option "Specify an IP address via DHCP", this setting is not overwritten when the project is loaded. If you select the option "Specify an IP address", you can also configure the network address in the WinCC device configuration and load it to the HMI device together with the project.

Ethernet parameters Port

Activate this port for use

Mode and speed:

- "Activate this port for use": Option to enable or disable the port. The default setting is "activated".
- "Mode and speed": List for selecting the transmission mode and transmission speed for the interface.

Selection options:

- "Automatic" (default setting)
- "10Mbps / HDX" (10 Mbps, half duplex)
- "10Mbps / FDX" (10 Mbps, full duplex)
- "100Mbps / HDX" (100 Mbps, half duplex)
- "100Mbps / FDX" (100 Mbps, full duplex)

The preferred default setting is "Automatic".

Name servers

Name server address may be automatically assigned if DHCP is enabled on this adapter.

Primary DNS:

Secondary DNS:

- "Primary DNS": Address of the primary DNS server.
- "Secondary DNS": Address of the secondary DNS server.

If you have activated the "Obtain an IP address via DHCP" option under "IP address", the specifications under "Name servers" are optional.

5.6 Security

5.6.1 User management

A convenient user management is available to you under "User management". The user management is configured in WinCC, transferred to the HMI device and managed on the HMI device.

Web access is also available for user management, see "Web access to the HMI device (Page 54)".

Note

Important information on the configuration and project transfer

- If you do not assign a user a role or a role and no function right in the configuration, the user or the role is not loaded to the device.
In WinCC, configure all roles required on the HMI device with all function rights required on the HMI device. Assign each role required on the HMI device to at least one user.
- To transfer the user management from WinCC to the HMI device, the option "Keep current user management data in runtime" must be **disabled** in the "Load preview" dialog during project transfer (Page 105) .

You can find detailed information on configuration in the TIA Portal Help under "Visualizing processes (RT Unified) > Configuring users and roles (RT Unified)".

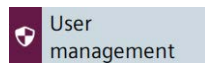

The complete user list is only visible and editable for users who have been assigned the "User management" function right in the configuration.

Users with other function rights see their own entry in the user list and can only use the buttons in the "Current user" area.

When password protection is enabled for the Control Panel, only users with the "Control Panel access" function right can access the Control Panel.

The password guidelines are specified during configuration. The function rights of a user are valid for the Control Panel as well as for the runtime software.

Current user

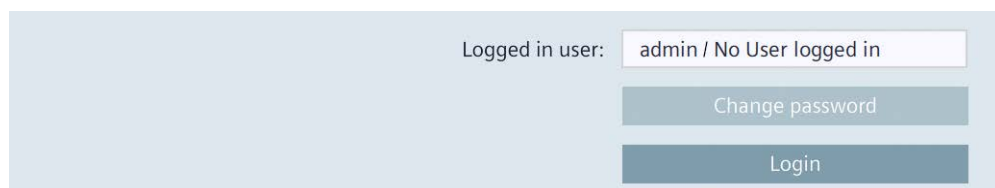

- "Logged in user": Displays the login name of the user currently logged in. If no user is logged in yet, then "No User logged in" is displayed.
- "Change password": Button to change the password for the user currently logged in. After pressing the button, the "Change password" dialog is displayed.

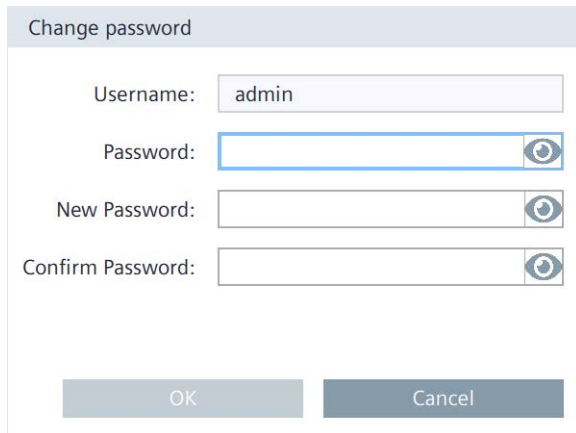

A dialog box titled "Change password" with a light blue header. It contains four input fields: "Username:" with the text "admin", "Password:", "New Password:", and "Confirm Password:". Each password field has a small eye icon to its right. At the bottom, there are two buttons: "OK" and "Cancel".

Enter the previous password once and the new password twice. The following button can be used to make the passwords visible for the display duration of the dialog box:



- "Change user": Button for changing the current user.
- "Login": Button for logging in a user.

After pressing the button, the "User Login" dialog is displayed.

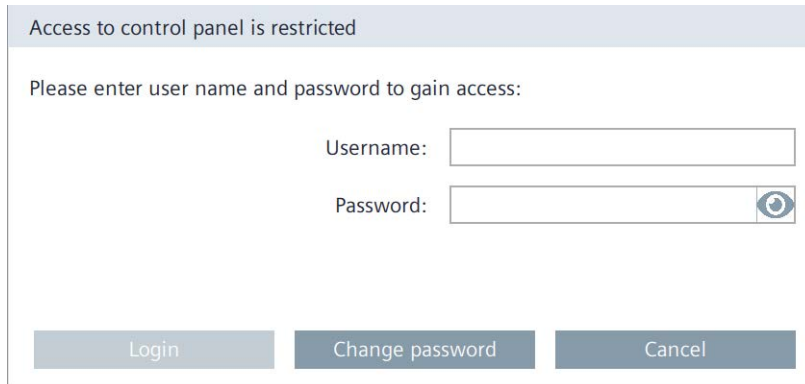

A dialog box titled "Access to control panel is restricted" with a light blue header. Below the header, it says "Please enter user name and password to gain access:". There are two input fields: "Username:" and "Password:". The "Password:" field has an eye icon to its right. At the bottom, there are three buttons: "Login", "Change password", and "Cancel".

Enter the desired login name with the associated password and log in using the "Login" button.

Note

Number of login attempts

The number of attempts for the correct entry of the login credentials can be configured in WinCC under "Runtime settings > Security".

If the login credentials are entered incorrectly one more time, the user involved will be locked. The user must be deleted and recreated, or you must reload the User Management into the HMI device.



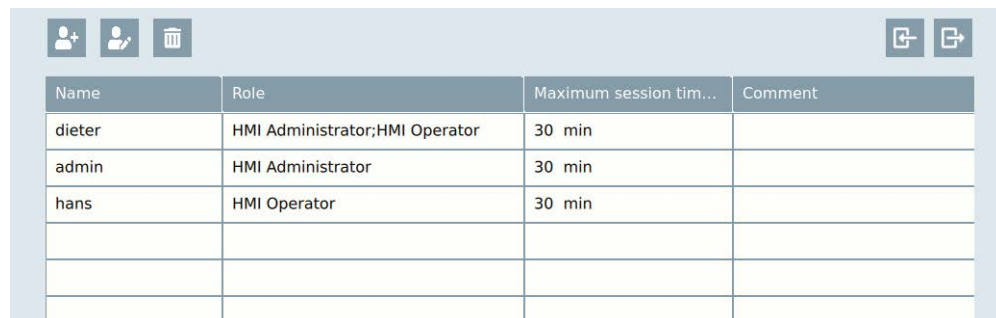

Ensure you enter the login credentials correctly.

Users



Name	Role	Maximum session tim...	Comment
dieter	HMI Administrator;HMI Operator	30 min	
admin	HMI Administrator	30 min	
hans	HMI Operator	30 min	

- Above the user list are the following buttons with the following functions for users with the "User management" function right:

	Create a new user.
	Edit data of the user currently selected in the list.
	Delete the user currently selected in the list.
	Import complete user management from a ".json" file on an external storage medium. ¹ Note: Import completely overwrites the user management on the HMI device.
	Export complete user management to a ".json" file on an external storage medium. ¹

¹ For importing and exporting the user management, the "User management" function right is required; the "Import and export users" function right, which can be configured in WinCC, is not required.

- The user list displays the users available on the HMI device with the following user characteristics:
 - "Name": Login name of the user.
 - "Role": Roles assigned to the user.
 - "Maximum session timeout": This value indicates the number of minutes after which the user is automatically logged off if they no longer perform any operator action.
Value range: 0 to 600 minutes (0 = automatic logout disabled).
 - "Comment": Comment text for the user.

Note

You cannot edit or delete yourself as a user.

To ensure that at least one user with the "User management" function right remains on the HMI device, users cannot edit or delete themselves. A second user with the "User management" function right is required for this purpose.

Note

Maximum session timeout

In the Engineering System, you can configure a maximum session duration for a role as well as for a user. If these values differ, only the smaller of the two values is transferred to the Panel during loading.

Creating or editing users

The editing functions are only available for users who have been assigned the "User management" function right in the configuration.

Use the following button to create a new user:



With the following button you edit the data of a user:



After pressing one of the two buttons, the dialog "Add user" or the dialog "Edit user" is displayed. Both dialog boxes are identical in content.

The following figure shows an example of the "Edit user" dialog box.

- "Login user name": Display field with the login name of the user.
- "Role": Drop-down list for assigning the user to one or more roles. The roles are defined in the WinCC project for the HMI device and assigned the corresponding function rights.

The following system-defined roles are always transferred to the HMI device:

Role designation	Authorization in the Control Panel	Authorization in Runtime
HMI Operator	-	Web access, Operate, Monitor
HMI Monitor	-	Web access, Monitor
HMI Monitor Client	-	Web access, monitoring without influencing the processes in the controller
HMI Administrator	User management, Import and export users, Control panel access	Remote access, Monitor, Operate, Web access

The drop-down list also contains the configured roles that were transferred from the WinCC project to the HMI device.

Note

The HMI role "HMI Monitor Client" is superior to all other roles and their function rights. A user to whom the role "HMI Monitor Client" is assigned gets the function rights of only that role. Any superior function rights of other roles that are assigned to the user will be lost.

You can find detailed information on users, roles, and function rights in the TIA Portal Help.

- "Password": Text box for the password of the user. If you do not enter anything, the user's existing password remains unchanged.
- "Confirm password": Text box for confirming the password.
- "Maximum session timeout": This value indicates the number of minutes after which the user is automatically logged off if they no longer perform any operator action.
Value range: 0 to 600 minutes (0 = automatic logout disabled).
- "Comment": Note on changing the user.
- "Edit user" or "Add user" Button for saving the user.
- "Cancel": Button for discarding the changes.

5.6.2 Certificates

You can use this function to import, display and delete certificates and certificate revocation lists.



A digital certificate consists of structured data, which confirms ownership and other properties of a public key.

When handling certificates, note the information on Industrial Security (Page 17).

Certificates on the device

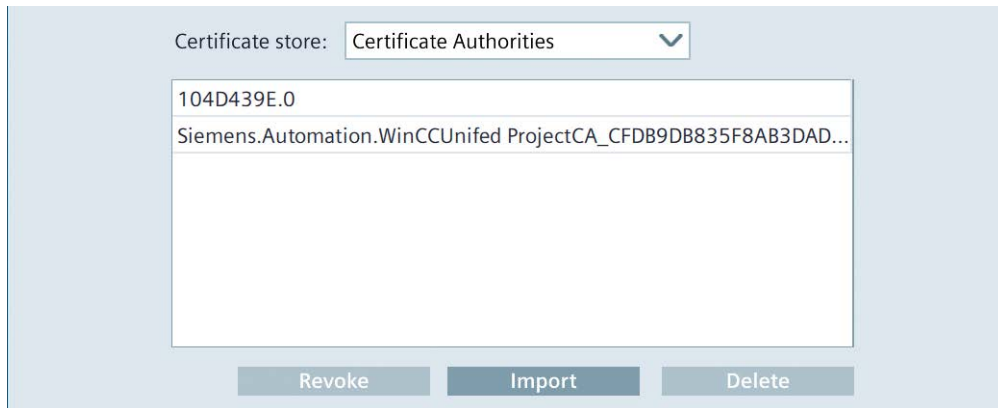

- "Certificate store": Drop-down list for the following certificate categories:
 - "Certificate Authorities": Trusted root certificate authorities and intermediate certificate authorities.
 - "My Certificates": Application certificates, such as for OPC UA client/server communication.
 - "Other Certificates": Self-signed end entity certificates and trusted end entity certificates.
 - "Certificate Revocation Lists" for certificate revocation lists.
- The certificate list displays the certificates of the selected category. If you select an entry in the list, then the "Certificate details" for certificates or the "CRL details" for certificate revocation lists are displayed below the list.
- "Revoke": Button to mark a certificate as not trustworthy. This function is only available in the "Other Certificates" certificate category.
- "Trust": Button to mark a certificate as trustworthy. This function is only available in the "Other Certificates" certificate category.
- "Import": Button for importing one or more certificates from a data storage medium.

Note

Supported file formats for certificates

The import function supports certificate files of type ".enc", ".der", ".crl" and ".pem".

Files of type ".enc" are exported from the "WinCC Unified Certificate Manager" and contain a collection of keys, certificates and CRLs.

If you want to import an individual cryptographic file, the supported formats for CER and CRL files end in ".pem" and ".der". The individual file should have a CA certificate or a CRL with extension ".der", ".crl" or ".pem".

The "Import certificate" dialog is displayed after the "Import" button has been pressed.

Select the storage medium and certificate file and import the certificate file using the "Import" button.

When you import an encrypted certificate with the ".enc" file extension, enter the following additional data:

- "Password": The encryption password that was specified when the certificate was generated.
- "Iteration": The iteration count that was specified when the certificate was created.
- "Delete": Button to delete the currently selected certificate in the certificate list.

Note

The selected certificate is deleted immediately without prompt.

Certificate details

- "Certificate name": Name of the certificate.
- "Status": Status of the certificate on the HMI device ("Trusted" or "Revoked"). This display field is only available in the certificate category "Other Certificates".
- "Thumbprint": Character string to prove the authenticity of the certificate.
- "Valid from": Start of the validity of the certificate.

- "Valid to": End of the validity of the certificate.
- "Issued to": Recipient of the certificate.
- "Issued by": Issuer of the certificate.

CRL details

CRL name	Siemens_Automation_CA_2019
Issuer:	Siemens Automation CA 2019
CRL number	3
Last update	Mar 29 00:00:00 2020 GMT
Next update	Mar 27 23:59:59 2029 GMT
Thumbprint:	9D:B2:1D:7A:E9:7A:70:29:BD:C3 49:22:7E:F9:0A:27:FC:4C:47:D9
CRL count	16

- "CRL name": Designation of the certificate revocation list.
- "Issuer": Issuer of the certificate revocation list.
- "CRL number": Consecutive version number of the certificate revocation list.
- "Last update": Time of creation of this certificate revocation list.
- "Next update": Time of creation of the next certificate revocation list.
- "Thumbprint": Character string to prove the authenticity of the certificate revocation list.
- "CRL count": Number of entries in the certificate revocation list.

5.6.3 Control panel access

Under "Control panel access" you can protect access with a password on the Control Panel. Only users who have been assigned the "Control Panel access" function right in the configuration can change the password protection.

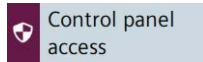

Control panel access

Enable password protection for control panel

- "Enable password protection for control panel": Option to enable password protection for the Control Panel.

The password protection can only be activated or deactivated by users who have been assigned the "Control Panel access" function right in the configuration.

If you are not yet logged in as a user with the "Control Panel access" function right and enable the option "Enable password protection for control panel", the "Access to control panel is restricted" dialog is displayed.

Access to control panel is restricted

Please enter user name and password to gain access:

Username:

Password:

Login
Change password
Cancel

Log in as a user with the "Control Panel access" function right to activate the password protection for the Control Panel. Use the following button to make the password visible for the display duration of the dialog:



Note

Number of login attempts

The number of attempts for the correct entry of the login credentials can be configured in WinCC under "Runtime settings > Security".

If the login credentials are entered incorrectly one more time, the user involved will be locked. The user must be deleted and recreated, or you must reload the User Management into the HMI device.

Ensure you enter the login credentials correctly.

Note

Password protection of the Control Panel and project transfer

When access to the Control Panel is protected, you must ensure that the user management has been configured correctly in the TIA Portal before transferring a project again. This means:

- A user with "Control Panel access" right has been configured.
- When central user management is being used, all data for accessing the UMC server has been entered correctly.

Recommendation:

- Before loading again, disable the "Enable password protection for control panel" option.
 - After loading, verify that the user with the "Control Panel access" right can log in. If this is not the case, correct the configuration of the user management.
 - Enable the "Enable password protection for control panel" option again.
-

If you are logged in as a user with the "Control Panel access" functional right, the "Access to control panel is restricted" dialog is no longer displayed when accessing the Control Panel.

If you are not logged in or do not have the "Control Panel access" function right, the "Access to control panel is restricted" dialog is displayed when accessing the Control Panel.

Access to the Control Panel can be triggered directly in the Control Panel or via a system function of the Runtime software.

5.6.4 UMAC settings

Under "UMAC settings", you can see whether local or central user management is used on the HMI device.

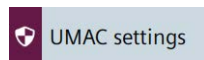

The local or central user management is configured in WinCC and transferred to the HMI with the download.

Note

You can only switch between local and central user management in WinCC.

When loading the central user management, all local users on the HMI device are deleted.

Configuration of user management

Use local user management (users stored on this device)
 Use central user management (users taken from server)

Server address:

Server-ID:

Generate address of identity provider automatically

Address of identity provider:

Connection status:

- "Use local user management (users stored on this device)": Information that local user management is used. The data in this window cannot be edited; the users are managed locally under "Security" > "User management".
- "Use central user management (users taken from server)": Information that central user management is used. The connection settings are configured in WinCC and transferred to the device during loading. The settings on the HMI device can be adjusted, if required.

Meaning of the connection settings for central user management:

- "Server address": IP address or device name of the UMC server.
- "Server-ID": Unique string for identification of the UMC server. You can enter the server ID manually or have it determined automatically during connection setup.
- "Generate address of identity provider automatically": Option for automatic generation of the address of the ID provider on the UMC server. The default setting is "enabled". Disable this option if you do not want to use the UMC server but a different server as ID provider. This may be necessary when using a server farm, for example.
- "Address of identity provider": Address of the ID provider either generated automatically via the option "Generate address of identity provider automatically" or entered manually, if necessary.
- "Connection status": Connection status to the UMC server, possible values:
 - <empty>: The connection to the UMC server has not been tested yet.
 - "Connected": The connection to the UMC server has been established and tested.
 - "Not connected" - <error message>: There is no connection to the UMC server. The <error message> provides information about the possible cause.
 - "Connection not possible" - <error message>: The connection to the UMC server could not be set up. The <error message> provides information about the possible cause.
- "Check connection": Button to check the connection to the UMC server.
- "Connect to server": Button to set up the connection to the UMC server.
- "Reset configuration": Button to delete the connection settings.

Establishing a connection to the central user management

When all connection settings have been configured correctly and transferred with the project to the HMI device, the HMI device is automatically connected to the central user management. No value is specified under "Connection status" because the connection has not been checked yet. Press the "Check connection" button to check the connection.

When the central user management has not been configured completely or is incorrect, you can adjust the settings on the HMI device. Press the "Connect to Server" button to connect the device to the central user management.

When the connection was set up successfully, the "Connected" information is displayed under "Connection status". The "Connect to server" button turns into "Check connection".

You can find more information in the TIA Portal Help under "Visualizing processes (RT Unified) > Configuring users and roles (RT Unified)".

5.7 External Devices and Input

5.7.1 Hardware interfaces

Under "Hardware interfaces", change the settings for accessing the storage media interfaces.

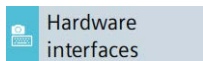

You can deactivate one or more interfaces to protect the HMI device from unauthorized external access.

Activate USB ports

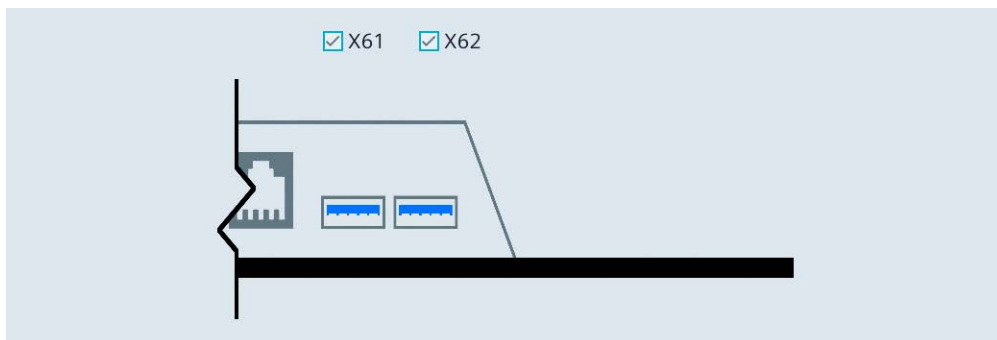

- "X61": Option to activate or deactivate the USB port X61.
- "X62": Option to activate or deactivate the USB port X62.

Default setting for all USB ports is "activated".

5.7.2 Connected devices

Under "Connected devices" you can show information on the storage media that are connected to the HMI device.

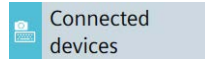

Select storage media

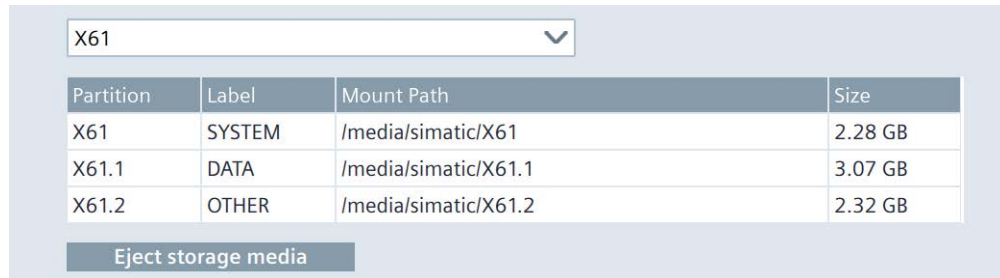

The drop-down list box shows all the storage media at the interfaces of the HMI device.

Select an entry to display detailed information on a storage medium in the partition list.

- This partition list contains the following information:
 - "Partition": Name of the partition. The first partition carries the designation of the interface to which the storage medium is connected, for example "X61".
If more partitions are present on the storage medium, they are numbered successively and shown delimited by a period below the first partition, for example, "X61.1".
 - "Label": Designation of the partition that was selected at the time of formatting.
 - "Mount Path": Path via which the HMI device accesses the partition.
 - "Size": Size of the partition.
- "Eject storage media": Button for securely removing the selected storage medium.

Note

Behavior of the "Eject storage media" function

- If data is still being accessed on the storage medium, the storage medium cannot be removed reliably. A corresponding error message is displayed. Confirm the error message with "OK" and execute the function again when the data access has ended.
 - After secure removal, the HMI device cannot access the storage medium. For renewed access, the HMI device must be restarted or the storage medium plugged in again. A corresponding warning is displayed. Confirm with "OK" or cancel the action with "Cancel".
 - After secure removal, the storage medium is not present in the selection list any more, and all the relevant entries in the partition list are removed.
-

5.8 Language, Region and Formats

5.8.1 Date and time

Under "Date and time", set the date, time, and time zone for the HMI device manually or via a time server on the network.

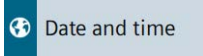

NOTICE
Setting the date and time correctly
When the date and time are not set correctly, malfunctions may occur in the plant. To prevent malfunctions, set the date and time of the HMI device and all controllers connected to the HMI device to the correct values or use an NTP server for time synchronization. Check the correct settings for date and time after every update of the operating system.

NOTICE
Time synchronization required for time-dependent reactions
A malfunction may occur in the plant if the date and time are not synchronized and time-dependent reactions are triggered in the plant via the HMI device. To avoid malfunctions, use automatic time synchronization via one or more NTP servers.

Date and time

A screenshot of the "Date and time" configuration interface. It features three input fields: "Date" with the value "24 November 2023", "Current Time" with the value "15:20:31", and "Time zone" with a dropdown menu showing "(UTC) Coordinated Universal ...". Below these fields are two radio button options: "Set date and time manually" (which is selected) and "Synchronize time with a NTP (Network Time Protocol) server".

- "Date": Display field with the current date.
- "Current Time": Display field with the current clock time.
- "Time zone": Selection list for the desired time zone.

Note

Automatic daylight saving/standard time switchover

If you select a time zone in which there is a switchover between daylight saving and standard time, the switchover takes place automatically on the relevant date.

- "Set date and time manually" (default setting): Option for manual time setting on the HMI device. If you select this option, the following list is displayed below the options:

19	August	2020	06	47
20	September	2021	07	48
21	October	2022	08	49
22	November	2023	09	50
23	December	2024	10	51
24	January	2025	11	52
25	February	2026	12	53

Set Date and Time

Set the day, month, year and time by scrolling the respective list column so that the desired date and time are displayed in the framed line in the middle of the list. The "Set Date and Time" button is used to save the setting.

- "Synchronize time with a NTP (Network Time Protocol) server": Option for automatic time synchronization via an NTP server. If you select this option, the following parameters for specifying time synchronization via NTP servers are displayed below the options:

Update rate: sec

Server 1

Address: 

Add Server

Enter the desired synchronization interval under "Update rate", value range 10 to 86400 seconds (1 day). After the input, the value is rounded to the nearest power of two based on the internal format.

Add at least one and a maximum of four NTP servers using the "Add Server" button. Specify the IP address for each NTP server and make sure that the device is set up as an NTP server.

5.9 Service and Commissioning

5.9.1 Transfer

Under "Transfer" you define whether and how data is transferred from a configuration PC to the HMI device.

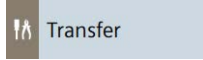

Transfer mode



- "Enable transfer": Option to enable or disable data transfer to the HMI device. The default setting is "enabled".

If you disable the transfer, you protect the HMI device against unintended update of the operating system and overwriting the project data.

Encrypted project transfer



- "Password": Password for the encrypted transfer of the project. The password must match the password that was specified in the configuration under the runtime settings of the HMI device.

To enter the password, tap the entry field.

- "Set Password": Button to save the password for the encrypted project transfer.

As an alternative, you can transfer the password unencrypted during the initial loading of the project.

5.9.2 Update OS

The firmware and operating system version of the HMI device must be compatible with the firmware and operating system version of the installed WinCC software. If this is not the case, then you must update the operating system.

Use "Update OS" to update the operating system of the HMI device. The operating system is contained in several firmware files. The master file has the extension ".fwf". The number of additional files varies; these files have the file name of the master file and a sequential number (".0", ".1", ".2", etc.) as an extension.

The "Update OS" function is available under both "System Properties" and "Service and Commissioning".

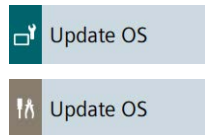

NOTICE

Updating the operating system deletes data on the HMI device

Project, parameter sets and user administration will be deleted when you update the operating system on the HMI device.

Before updating the operating system, backup the data on the HMI device, if necessary.

All settings, except the following settings which you changed in the Control Panel before updating the operating system, are retained even after the update of the operating system:

- The external interfaces become activated again (default setting), see section "Hardware interfaces (Page 90)".
- The time zone is reset to the default setting "(UTC) Coordinated Universal Time", see section "Date and time (Page 92)".

Use an industrial USB flash drive to load the firmware.

Firmware files for the HMI devices can be downloaded from the Internet (<https://support.industry.siemens.com/cs/ww/en/view/109746530>). Observe the documentation included with the download.

Note

Do not rename firmware files

If you change the name of the firmware files, the operating system can no longer be updated with these firmware files. The firmware files become unusable. Leave the name of the firmware files unchanged.

Note

Copy firmware files completely

If you copy the firmware files, be sure to also copy the master file ".fwf" together with all associated firmware files (".0", ".1", ".2", etc.).

If one of the files is missing, the operating system cannot be loaded.

Alternatively to the "Update OS" function in the Control Panel, you can use the "Update OS" function in WinCC.

Panel Information

Device type:

Image version:

- "Device type": HMI device type designation.
- "Image version": Version of the firmware and operating system.

Select storage media for OS update

▾

Use the selection list to select the storage medium on which the firmware file is located.

Firmware files on external storage

Name	Path	Image Version
UBP_4_12_V19_0.fwf	/media/simatic/data-s...	V19.00.00.01_00.01...
UBP_4_12_V19_0.fwf	/media/simatic/data-s...	V19.00.00.01_00.01...
UBP_4_12_V19_0.fwf	/media/simatic/data-s...	V19.00.00.01_00.01...

- The list shows all firmware files that can be loaded into the HMI device. Select the desired firmware master file (.fwf) from the list.
- "Update OS": Button for starting the loading process. The HMI device restarts after the "Update OS" button is pressed. The loading process then begins. A dialog with a progress bar is displayed on the HMI device for each firmware file. The HMI device is restarted again after the completion of the loading process. The main window of the Control Panel is displayed after the restart. The operating system on the HMI device is updated.

5.9.3 Backup

Under "Backup" you can back up the operating system, applications and data from the flash memory of the HMI device to an external storage medium.

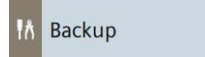

Use an industrial USB flash drive as the storage medium.

Depending on the amount of data on the HMI device, a backup may require up to 20 GB of memory. Make sure that the storage medium has sufficient free space. Recommendation: At least 5 GB of free space on the storage medium.

Do not turn off the HMI device during the backup process.

Select storage media

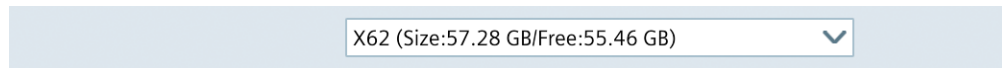

Select the storage medium on which you want to back up the data.

Complete backup file

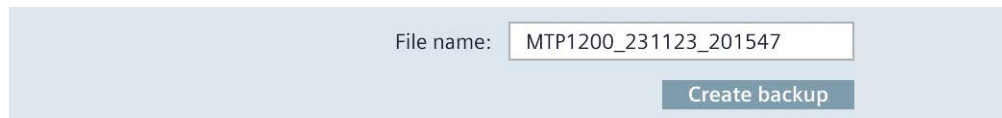

- "File name": Name of the backup. Select a name that best identifies the backup. A backup includes multiple files. The master file has the extension ".brf". The number of additional files varies; these files have the file name of the master file and a sequential number (".0", ".1", ".2", etc.) as an extension.

- "Create backup": Button to start the backup process.

After the "Create backup" button has been pressed, the system checks whether a backup with the name specified under "File name" already exists on the storage medium. If yes, then a warning is displayed. Select "OK" to overwrite the backup or "Cancel" to specify a different name for the backup.

The backup process starts with a restart of the HMI device, followed by the data backup.

During the data backup, a folder with the name of the backup is created in the root directory of the selected storage medium. The backup files are saved in this folder. A dialog with a progress bar is displayed for each backup file.

The HMI device is restarted again after the completion of the backup process.

The main window of the Control Panel is displayed after the restart.

The data of the HMI device are saved on the storage medium.

Note

Do not rename backup files on the data storage medium

If you change the name of the backup files on the data storage medium, these backup files can no longer be loaded into the HMI device using the "Restore" function.

Leave the name of the backup files on the data storage medium unchanged.

Note

Copy backup files completely

If you copy the backup files, be sure to also copy the master file ".brf" together with all associated backup files (".0", ".1", ".2", etc.).

If one of the files is missing, the backup cannot be loaded.

See also

Accessories (Page 14)

Backup and restore (Page 108)

5.9.4 Restore

Under "Restore", you can restore the backup of an HMI device from a storage medium.

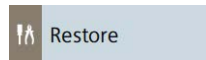

Remote access to the HMI device is not possible during the restore process.

A restore operation deletes the flash memory of the HMI device on confirmation. The data backed up on the storage medium is then transferred.

NOTICE

Data loss

All data on the HMI device, including the project and HMI device password, is deleted during a restore operation. License keys are only deleted after a security prompt.

Back up your data before the restore operation, if necessary.

Select storage media

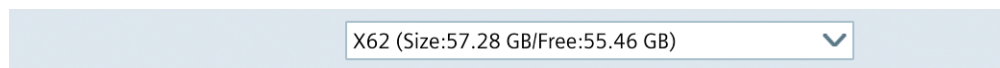

Select the storage medium on which the backed-up data is stored.

Backup files

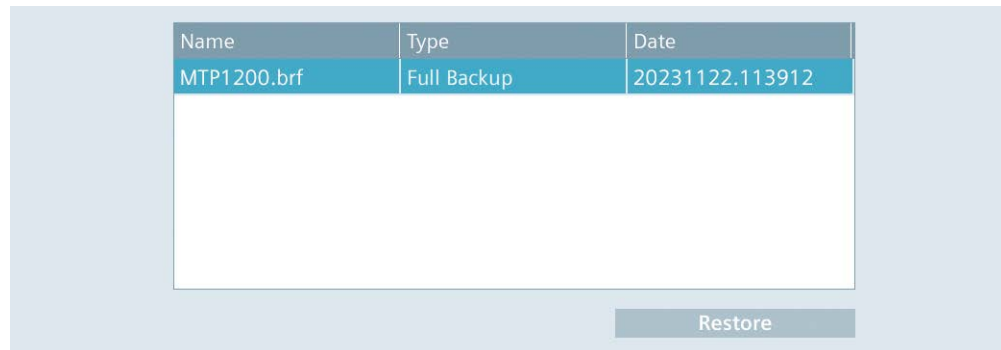

Name	Type	Date
MTP1200.brf	Full Backup	20231122.113912

Restore

- The list shows all backups that can be loaded to the HMI device.
Select the desired backup from the list.
- "Restore": Button to start the restore process.
The HMI device restarts after the "Restore" button is pressed. The restore process then begins.
Do **not** switch off the HMI device during the restore process and do **not** disconnect the data source from the HMI device.
During the restore process, a dialog with a progress bar is displayed for each backup file loaded.
The HMI device is restarted again after the completion of the restore process.
The main window of the Control Panel is displayed after the restart.
The data from the storage medium is now restored on the HMI device.

Note

System behavior when the process is interrupted

If the restore process cannot be completed due to a power failure or an interrupted data connection, for example, the HMI device starts in maintenance mode and the factory settings must be restored.

See also

Resetting an HMI device to factory settings via ProSave (Page 113)

5.9.5 Trace options

You specify whether or not trace outputs are displayed and backed up on an external storage medium under "Trace options".

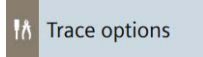

Note

The settings of the "Trace options", i.e. the settings for "Trace forwarder" and "Trace logger", are retained after restarting the HMI device or updating the operating system.

Trace forwarder

Enable Trace forwarder

- "Enable Trace forwarder": Option to enable or disable the "tracing" service. The default setting is "deactivated".

Enable "Tracing" for diagnostics and service purposes, e.g. to display trace outputs from scripts. If you start the HMI device in maintenance mode, the "Tracing" function is automatically enabled. You can find additional information in FAQ Entry 109777593 on the Internet (<https://support.industry.siemens.com/cs/ww/en/view/109777593>).

Trace logger

Enable Trace logger

Enable log rotate

Storage Medium: X51 (Size:1.91 GB/Free:1.89 ...

Select Path:

Maximum Log File Size (MB)

Maximum Log File Count

- "Enable Trace logger": Option to back up "tracing" information on an external storage medium. The default setting is "deactivated".
- "Enable log rotate": Option for activating the "Log rotate" function. The default setting is "deactivated". This option can only be activated in conjunction with "Enable Trace logger". If "Log rotate" is activated, then the "tracing" information is successively saved in several files with a specified size ("Maximum Log File Size") on the selected storage medium. If the maximum size of the first log file is reached, then another log file is automatically created, which is written to. When the maximum size of the last log file ("Maximum Log File Count") has been reached, the oldest log file at that time will be deleted and a new log file will be created to back up the further "tracing" information.
- "Storage Medium": Storage medium on which the "tracing" information is to be backed up.

- "Select Path" (optional): Path to location where the "tracing" information is to be backed up. The name of the path must begin with "/" and may contain only Latin characters and **none** of the following special characters: ! # \$ % & () * + , ; < = > ? @ [] _ { | } ~ ^

Log files on the selected storage medium

The log files with the "tracing" information are always saved in a subdirectory "/TraceLogs" on the selected storage medium.

If no path is specified, you can find the log files in the "/TraceLogs" directory.

If a path is specified, you can find the log files here "<path>/TraceLogs" directory.

In the figure above, the path "/traces" is given as an example. You can find the relevant log files under "/traces/TraceLogs".

Names of the log files

The log files are named, with the date and time, according to the following syntax:

TraceLogs-YYYY-MM-DD-T_HH_MM_SS.log

- "Maximum Log File Size (MB)": Maximum size of a log file in megabytes. Permitted range: 10 MB to 2000 MB. Default setting: 10 MB.
- "Maximum Log File Count": Maximum number of log files that can be created.
 - Minimum value: 2 (default setting).
 - The maximum value results from the size of the free storage space on the selected storage medium.

If the product of the values specified under "Maximum Log File Size (MB)" and "Maximum Log File Count" exceeds the size of the available storage space on the selected storage medium, then the values are marked as incorrect and must be corrected.

Transferring data

6.1 Overview

Configuration phase

In the configuration phase, the automation process is visualized with the configuration software in the form of a project. The plant screens of the project contain operating elements and display controls for values and alarms which provide information about process statuses. After the configuration phase, the project is transferred to HMI device, followed by the process control phase.

Transferring the project to the HMI device

The project must be transferred to the HMI device to be used in process control. You have the following options for the transfer:

- Transfer the project from a configuration PC to the HMI device, see section "Transferring a project with WinCC (Page 105)".
- Transfer of the project from an external storage medium, see section "Load project from storage (Page 73)".
- Restore the backup file of an identical HMI device from an external storage medium, see section "Restore (Page 98)".

Updating the operating system of the HMI device

The firmware and operating system version of the HMI device must be compatible with the firmware and operating system version of the installed WinCC software. If this is not the case, an error message is output before the transfer.

You can update the operating system of the HMI device in the following ways:

- Transfer of the operating system together with the project from a configuration PC to the HMI device, see section "Transferring a project with WinCC (Page 105)".
- Transfer of the operating system from a configuration PC to the HMI device, see section "Updating the operating system via WinCC (Page 112)".
- Transfer of the operating system from a data storage medium to the HMI device, see section "Update OS (Page 95)".
- Restore the backup file of an identical HMI device from an external storage medium, see section "Restore (Page 98)".

If the operating system cannot be updated with the above options, then you must reset the HMI device to factory settings.

You can reset the HMI device to the factory settings in the following ways:

- If the HMI device starts and you have access to the Control Panel, proceed as described in section "Resetting an HMI device to factory settings via ProSave (Page 113)".
- If the HMI device does not start or you do not have access to the Control Panel of the HMI device, then start the HMI device in maintenance mode, see section "Using the maintenance mode (Page 116)".

Process control phase

In the process control phase, the HMI device is connected online to a controller, and you can operate and monitor the plant.

Commissioning and recommissioning

Initial commissioning and recommissioning differ as follows:

- During initial commissioning, no project is available on HMI device. The HMI device has this status when delivered and after updating of the operating system.
- When recommissioning, the project already on the HMI device is replaced.

6.2 Operating modes

Operating modes

The HMI device can be in the following operating modes:

- Offline
- Online
- Transfer

Changing the operating mode

The configuration engineer must have configured appropriate operating elements to allow a change of the operating mode on the HMI device during ongoing operation.

If available, you can find additional information in your plant documentation.

"Offline" operating mode

In this mode, there is no communication between the HMI device and the controller. Even though the HMI device can be operated, it cannot exchange data with the controller.

"Online" operating mode

In this operating mode, there is a communication connection between HMI device and the controller or between HMI device and the configuration PC.

- In online operation between HMI device and controller, operate the plant with the HMI device according to the configuration.
- In online operation between HMI device and configuration PC, extended functions such as "Online & diagnostics" are available.

"Transfer" mode

In this mode, you can transfer a project from the configuration PC to the HMI device or backup and restore HMI device data, for example.

6.3 Using existing projects

Information and support for migration of existing projects is available:

- In the TIA Portal Help under "Editing projects > Compatibility of projects > Upgrading projects".
- In the entry "Data2Unified Add-in" for switching to SIMATIC WinCC Unified on the Internet (<https://support.industry.siemens.com/cs/ww/en/view/109770510>).

6.4 Data transmission options

The following table shows the options for data transmission between an HMI device and the configuration PC.

Interface	PROFINET (LAN)		USB
	Protocol	X1	X61/X62
Backup and Restore	PN/IE	-	x
	Ethernet	x	
Update operating system	PN/IE	-	x
	Ethernet	x	
Update operating system and Reset to factory settings	PN/IE	-	-
	Ethernet	x	
Transfer a project	PN/IE	x	x
	Ethernet	x	
S7 communication	PN/IE	x	-
NTP, Web client, Internet access	Ethernet	x	-

Notes on data transfer

If possible, use the "Ethernet" protocol for data transfer, which offers a higher speed than PN/IE.

Always use the "Ethernet" protocol for the "Update operating system via WinCC" function.

6.5 Setting the PG/PC interface

To establish Ethernet communication between the configuration PC and the HMI device, the PG/PC interface must be set correctly.

Procedure

1. Open the Control Panel of the configuration PC.
2. Click on "Set PG/PC interface".
3. Select the entry "S7ONLINE (STEP 7)" in the first tab under "Application access point".
4. Select your Ethernet adapter with the name suffix ".TCPIP.Auto.1" under "Used interface parameterization".

Result

The PG/PC interface is set, you can connect the configuration PC to the HMI device via Ethernet and transfer data.

6.6 Transferring a project with WinCC

This section describes how to transfer a project to the HMI device via the configuration software WinCC . Before the transfer, the software checks whether the project can be loaded onto the HMI device. The result of the check is displayed in the "Load preview" dialog box. If it is not possible to load the project, you can change the transfer settings in the "Load preview" dialog box. To load the project, use the configuration software with which the HMI device was configured.

Note

Existing parameter sets are deleted during loading

When loading a project into an HMI device, all parameter sets that were saved in the internal memory or on an external storage medium from the previous project are deleted. Before loading the project, save the parameter sets entered from the previous project.

Procedure

1. If a project is running on the HMI device, close the project.
2. Connect the HMI device to the configuration PC via the X1 interface.
3. In the Control Panel of the HMI device, select "Network and Internet" > "Network settings".
4. Ensure that the "Activate this port for use" option is enabled for the X1 interface under "Ethernet parameters Port".
5. In the Control Panel of the HMI device, select "Service and Commissioning" > "Transfer".
6. Make sure that the "Enable transfer" option is activated.



6.6 Transferring a project with WinCC

7. Open the configuration software with which the HMI device was configured.
8. Open the project you want to transfer to the HMI device.
Make sure that the port of the interface used for data transfer is activated in the project configuration. You can find this setting under the advanced options of the interface parameters in the device configuration.
9. In the project tree, select the HMI device whose project you want to transfer.
10. Select the "Download to device > Software" command in the shortcut menu of the HMI device.
11. If there is no connection to the HMI device, the connection dialog box is displayed. In this case, enter the connection settings for your HMI device. Click the "Connect" button and then click "Load".

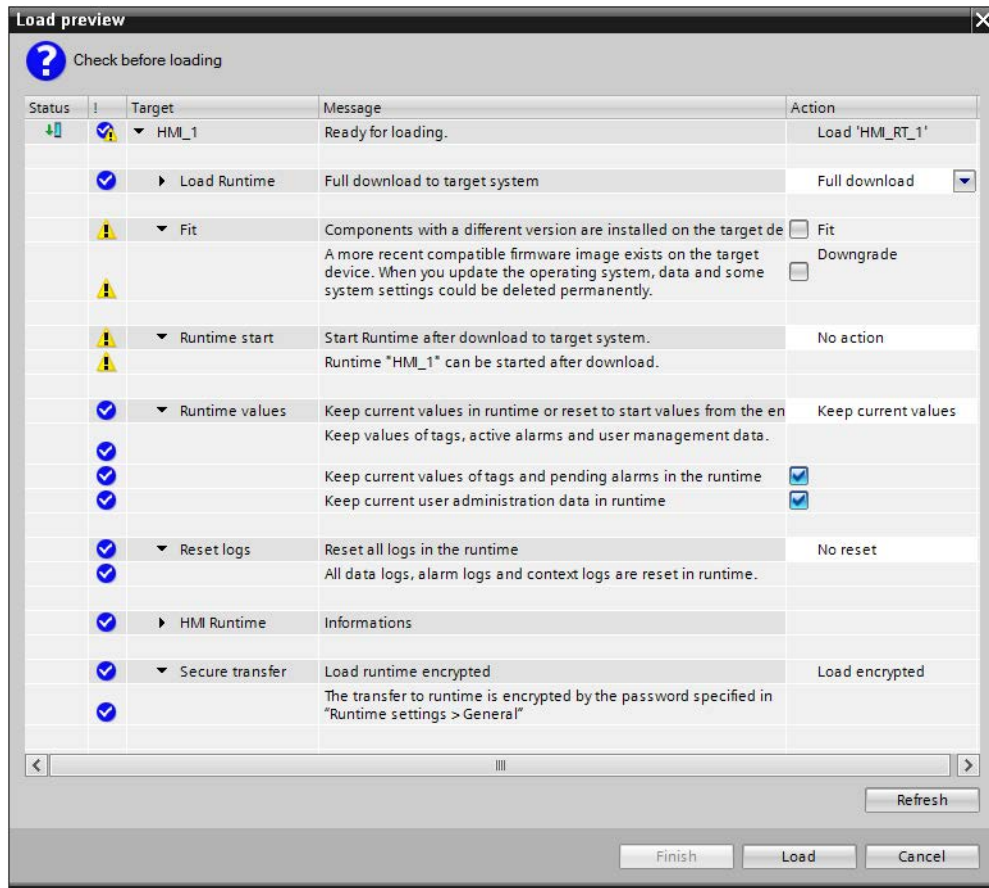
If the connection was established successfully, the "Load preview" dialog box is displayed. The following figure shows an example.



The "Load preview" dialog box contains alarms of type "Information" and "Warning".

	Information	The setting is compatible, the project can be loaded.
	Warning It is not possible to change the setting in the "Action" column.	The setting on the HMI device differs from the settings in the configuration software. The project can still be loaded with this setting.
	Warning The setting in the "Action" column can be changed.	Note that the setting on the HMI device is different from the setting in the configuration software. The project can be loaded after the setting in the "Action" column has been changed.
	Error It is not possible to change the setting in the "Action" column.	The project cannot be loaded. Adapt the setting in the configuration or on the HMI device.
	Error The setting in the "Action" column can be changed.	The project cannot be loaded. The project can be loaded after the setting in the "Action" column has been changed.

12. In the "Load preview" dialog box, specify the options for the loading process.

- "Load Runtime": Selection list for overwriting or keeping the runtime software on the HMI device.
- "Fit": In this area you define whether the version of individual components should be adjusted if the version of the component in the configuration differs from the version of the component on the HMI device. If the version on the HMI device is more recent, you can select "Downgrade", otherwise "Upgrade".

When you update the operating system via "Upgrade", observe the Important notes on updating the operating system (Page 111).

- "Runtime start": Selection list that allows you to specify whether the runtime software is started on the HMI device after loading or not.
- "Runtime values": In this area you define whether the data of tags, alarms and the user administration should be retained on the HMI device or not. If the respective option is selected, the data on the HMI device will be retained. If the respective option is cleared, then the data on the HMI device will be deleted or overwritten by the data in the configuration. If you want to update user administration on the HMI device, the "Keep current user administration data in runtime" option must be cleared.
- "Reset logs": Selection list for resetting or keeping all logs. If you select "Reset all", the data of all data logs, alarm logs and context logs are deleted on the HMI device.
- "HMI Runtime": This area contains information about runtime and firmware/operating system version of the HMI device.
- "Secure transfer": In this area you determine whether the project is transferred encrypted or not. Additional information is available in the section "Transfer (Page 94)".

If a warning with light red text is no longer displayed, the "Download" icon in the left "Status" column of the "Load preview" dialog is displayed in green and the "Load" button is activated.

13. Click "Load" to transfer the project to the HMI device.
The project is transferred to the HMI device. If errors or warnings occur during the transfer, alarms are displayed in the Inspector window under "Info> Download". After the successful transfer, the alarm "Load finished (errors: 0; warnings: 0)" is displayed.
14. In the Control Panel of the HMI device, select "Service and Commissioning" > "Transfer".
15. Clear the "Enable Transfer" option to protect the HMI device from an unintended transfer.

Result

The project is located on the HMI device and can be started. After the transfer, test the operating elements and screen changes in the "offline" mode. If all operating elements and screen changes function correctly, you can switch the HMI device to "online" mode.

6.7 Backup and restore

During data backup, the contents of the internal memory are saved in a backup on a configuration PC or on an external storage medium. Alarm logs and process value archives are not included in the backup. These archives are stored separately on an external storage medium. Back up these logs manually if required. If the HMI device is integrated in a network, you can also back up the data on a network drive.

The following data are saved in a backup:

- Operating system
- Control Panel settings
- Project and parameter sets
- User management

A backup includes several files. The master file has the extension ".brf". The number of additional files varies; these files have the file name of the master file and a sequential number (".0", ".1", ".2", etc.) as an extension.

Backup to the configuration PC

To back up the data of the HMI device, follow these steps:

1. If a project is running on the HMI device, close the project.
2. Connect the HMI device to the configuration PC via the X1 interface.
3. In the Control Panel of the HMI device, select "Network and Internet" > "Network settings".
4. Ensure that the "Activate this port for use" option is enabled for the X1 interface under "Ethernet parameters Port".
5. In the Control Panel of the HMI device, select "Service and Commissioning" > "Transfer".
6. Make sure that the "Enable transfer" option is activated.
7. Open the configuration software with which the HMI device was configured.
8. In the project tree, select the HMI device whose data are to be backed up.

9. Select the "Backup" command in the menu "Online > HMI Device maintenance" .
10. If there is no connection to the HMI device, the connection dialog box is displayed. In this case, enter the connection settings for your HMI device. Click on the "Connect" button and then on "Create".
If the connection was successfully established, the "Complete backup" dialog box with information about the project and the HMI device is displayed.
11. Click on the "Backup" button.
The "SIMATIC ProSave [Backup]" dialog box is displayed.
12. Under "Data type", select which data of the HMI device should be saved.
13. Enter the file name of the backup in the "Save as" field.
14. Click "Start Backup".

The backup process is started. A dialog with a progress bar is displayed for each backup file both in ProSave and on the HMI device. The update operation can take time, depending on the connection selected.

Note**Do not rename backup files on the data storage medium**

If you change the name of the saved backup files, these backup files can no longer be loaded into the HMI device using the "Restore" function. The backup files become unusable.

Leave the name of the backup files on the data storage medium unchanged.

Note**Copy backup files completely**

If you copy the backup files, be sure to also copy the master file ".brf" together with all associated backup files (".0", ".1", ".2", etc.).

If one of the files is missing, the backup cannot be loaded.

Backup to data storage medium on the HMI device

As an alternative to the configuration PC, you can also save the data via the Control Panel of the HMI device on a data storage medium that is directly connected to the HMI device, see section "Backup (Page 97)".

Restore from the configuration PC

To restore the data of the HMI device, follow these steps:

1. If a project is running on the HMI device, close the project.
2. Connect the HMI device to the configuration PC via the X1 interface.
3. In the Control Panel of the HMI device, select "Network and Internet" > "Network settings".
4. Ensure that the "Activate this port for use" option is enabled for the X1 interface under "Ethernet parameters Port".

5. In the Control Panel of the HMI device, select "Service and Commissioning" > "Transfer".
6. Make sure that the "Enable transfer" option is activated.
7. Open the configuration software with which the HMI device was configured.
8. In the project tree, select the HMI device whose data you want to restore.
9. Select the "Restore" command in the menu "Online > HMI Device maintenance" .
10. If there is no connection to the HMI device, the connection dialog box is displayed. In this case, enter the connection settings for your HMI device. Click the "Connect" button and then click "Load".
If the connection was established successfully, the "Complete restore" dialog box with information about the project and the HM device is displayed.
11. Click the "Restore" button.
The "SIMATIC ProSave [Restore]" dialog is displayed.
12. Under "Open from ..." enter path and file name of the backup.
13. Click "Start Restore".

The restore process is started. A dialog with a progress bar is displayed both in ProSave and on the HMI device for each backup file loaded. The update operation can take time, depending on the connection selected.

Do **not** switch off the HMI device during the restore process and do **not** disconnect the data source from the HMI device.

Note

System behavior when the process is interrupted

If the restore process cannot be completed due to a power failure or an interrupted data connection, for example, the HMI device starts in maintenance mode and the factory settings must be restored.

In this case, follow the procedure from step 6 in section "Resetting an HMI device to factory settings via ProSave (Page 113)".

Restore from a data storage medium on the HMI device

As an alternative to the configuration PC, you can also restore the data via the Control Panel of the HMI device from a data storage medium that is directly connected to the HMI device, see section "Restore (Page 98)".

6.8 Updating the operating system

6.8.1 Overview and important notes

The firmware and operating system version of the HMI device must be compatible with the firmware and operating system version of the installed WinCC software. If this is not the case, then you must update the operating system. If the operating system on the HMI device is no longer functional, you must reset the HMI device to factory settings.

NOTICE

Updating the operating system deletes data on the HMI device

Project, parameter sets and user administration will be deleted when you update the operating system on the HMI device.

Before updating the operating system, backup the data on the HMI device, if necessary.

All settings, except the following settings which you changed in the Control Panel before updating the operating system, are retained even after the update of the operating system:

- The external interfaces become activated again (default setting), see section "Hardware interfaces (Page 90)".
- The time zone is reset to the default setting "(UTC) Coordinated Universal Time", see section "Date and time (Page 92)".

When the operating system is reset to factory settings, all data of the HMI device is deleted and all settings in the Control Panel are reset to factory settings.

The operating system is contained in several firmware files. The master file has the extension ".fwf". The number of additional files varies; these files have the file name of the master file and a sequential number (".0", ".1", ".2", etc.) as an extension.

Firmware files for the HMI devices can be downloaded from the Internet (<https://support.industry.siemens.com/cs/ww/en/view/109746530>). Observe the documentation included with the download.

Note

Do not rename firmware files

If you change the name of the firmware files, the operating system can no longer be updated with these firmware files. The firmware files become unusable. Leave the name of the firmware files unchanged.

Note

Copy firmware files completely

If you copy the firmware files, be sure to also copy the master file ".fwf" together with all associated firmware files (".0", ".1", ".2", etc.).

If one of the files is missing, the operating system cannot be loaded.

You have the following options for updating the operating system or restoring the factory settings of the HMI device, provided that access to the Control Panel of the HMI device is working:

- Updating the operating system via WinCC (Page 112)
- Updating the operating system via external storage medium (Page 95)
- Resetting an HMI device to factory settings via ProSave (Page 113)

If access to the Control Panel of the HMI device no longer works, follow the procedure described in the section "Using the maintenance mode (Page 116)".

6.8.2 Updating the operating system via WinCC

The firmware and operating system version of the HMI device must be compatible with the firmware and operating system version of the installed WinCC software. If this is not the case, then you must update the operating system.

NOTICE
Do not switch off the HMI device during data transfer
If you switch off the HMI device while the operating system of the HMI device is being updated, the HMI device no longer starts. You must repeat the procedure.
Do not turn off the HMI device during data transfer.

Procedure

To update the operating system, follow these steps:

1. If a project is running on the HMI device, close the project.
2. Connect the HMI device to the configuration PC via the X1 interface.
3. In the Control Panel of the HMI device, select "Network and Internet" > "Network settings".
4. Ensure that the "Activate this port for use" option is enabled for the X1 interface under "Ethernet parameters Port".
5. In the Control Panel of the HMI device, select "Service and Commissioning" > "Transfer".
6. Make sure that the "Enable transfer" option is activated.
7. Open the configuration software with which the HMI device was configured.
8. In the project tree, select the HMI device whose operating system you want to update.
9. Select the "Update operating system" command in the menu "Online > HMI Device maintenance".
10. If there is no connection to the HMI device, the connection dialog box is displayed. In this case, select the "Ethernet" interface protocol, enter the IP address or name of the target device and click the "Connect" button and then "Update".
If the connection was established successfully, the "Update operating system" dialog box is displayed.

11. Under "Firmware file path ..." enter the path and file name of the firmware master file (.fwf) that contains the desired operating system.

12. Click "Update OS".

The update of the operating system is started. A dialog with a progress bar is displayed on the HMI device for each firmware file. The update operation can take time, depending on the connection selected.

Result

The operating system of the HMI device has been updated to the version of the selected firmware.

See also

Overview and important notes (Page 111)

Update OS (Page 95)

6.8.3 Resetting an HMI device to factory settings via ProSave

If the operating system on the HMI device is no longer functional, you must reset the HMI device to factory settings.

NOTICE
Do not switch off the HMI device during data transfer
If you turn off HMI device while the HMI device is being reset to factory settings, the HMI device will not start. You must repeat the procedure.
Do not turn off the HMI device during data transfer.

Procedure

To reset the HMI device to factory settings, follow these steps:

1. If a project is running on the HMI device, close the project.
2. Connect the HMI device to the configuration PC via the X1 interface.
3. In the Control Panel of the HMI device, select "Network and Internet" > "Network settings".
4. Ensure that the "Activate this port for use" option is enabled for the X1 interface under "Ethernet parameters Port".
5. In the Control Panel of the HMI device, select "System Properties" > "Reboot".

6.8 Updating the operating system

6. Press the "Reboot in maintenance mode" button. The HMI device starts. The "Maintenance Mode" dialog box is displayed for a period of 10 minutes. In this period you can connect the HMI device to a configuration PC and reset the HMI device to factory settings with the ProSave software. If the "Maintenance Mode" dialog is not displayed, start the HMI device while pressing the "Maintenance" button, see section "Using the maintenance mode (Page 116)".
7. Open the "ProSave" software on the configuration PC in the WinCC installation directory.
8. Enter the following data in the "General" tab:
 - "Device type": Select the type of your HMI device.
 - "Connection": Select "Ethernet".
 - "Connection parameters": Specify an IP address or computer name for the HMI device. The IP address must be located in the subnet of the configuration PC.
9. Enter the following data in the "OS Update" tab:
 - Under "Opening ...", select the path and file name of the firmware master file (.fwf) containing the desired operating system.
 - Select the option "Reset to factory settings".
 - Under "MAC", enter the MAC address which is shown at the top right of the HMI device display.
 - Use the "Device status" button to display information about the device and the selected firmware.
10. Click "Update OS". A dialog box with the warning that all data on the HMI device will be overwritten is displayed.
11. Confirm the dialog box.

The update of the operating system with "Reset to factory settings" is started. The progress of the update is displayed both in ProSave and on the HMI device. The update operation can take time, depending on the connection selected. The HMI device restarts at the end of the process.

Result

The operating system of the HMI device has been updated to the version of the selected firmware and the HMI device is reset to factory settings.

See also

Overview and important notes (Page 111)

Device maintenance and repair

7.1 General information on maintenance and servicing

Observe the following when servicing and repairing protective equipment such as ground circuits or overvoltage protection components:

- Observe the maintenance and replacement intervals specified by the manufacturer.
- Replace plant components, including external cables, fuses and batteries only with equivalent components approved by the respective manufacturer.

7.2 Cleaning the device front

7.2.1 Clean the glass front of the HMI device.

The HMI device is designed for low-maintenance operation. However, you should clean the glass front regularly.

Observe the information on chemical resistance (<https://support.industry.siemens.com/cs/ww/en/view/39718396>).

Important notes

Note**Avoid unintentional responses during cleaning**

If you clean the glass front when it is switched on, you may cause inadvertent operations via the touch screen.

When cleaning, switch off the HMI device or activate the clean screen function, if available.

Note**Avoid damage to the front**

The glass front may be damaged if compressed air or a steam jet is used and if aggressive solvents or abrasives are used.

Do not clean the glass front using compressed air or steam cleaners. Do not use aggressive solvents or scouring agents.

Requirement

- Damp cleaning cloth
- Dishwashing liquid or foaming screen cleaning agent

Procedure

Proceed as follows:

1. If a clean screen has been configured, activate it or stop the project and switch off the HMI device.
If a clean screen has not been configured, stop the project and switch off the HMI device.
2. Spray cleaning agent onto the cleaning cloth.
Do not spray cleaning agent directly onto the HMI device.
3. Clean the glass front.
When cleaning the glass front, wipe from the inside to the outside.

7.2.2 Notes on the clean screen

The touch screen of the HMI device can be cleaned when it is switched on and a project is running. An operating element must be available in the project that can be used to call the clean screen. Once the clean screen is activated, touch screen operation is locked for a configured period of time.

Note

Unintentional responses

When cleaning the touch screen, an unintentional response in the controller can be triggered by touching keys.

Always open the clean screen or switch off the HMI device before you clean the touch screen while the system is running.

Note

Cannot be operated when the clean screen is active

When the clean screen is active, operations on the HMI device are not possible.

Wait for the period of the clean screen to lapse. Then you can operate the system again with the HMI device.

7.3 Using the maintenance mode

Maintenance mode is used to reset the HMI to the factory settings.

When the operating system starts and the Control Panel is displayed after the HMI device is switched on, you can start the HMI device in maintenance mode by clicking the "Reboot in maintenance mode" button. Follow the description in section "Resetting an HMI device to factory settings via ProSave (Page 113)".

If the HMI starts with the boot splash screen and detects the corrupt operating system, the HMI automatically switches to maintenance mode. The "Maintenance Mode" dialog box is displayed. In this case, follow the procedure from step 6 in section "Resetting an HMI device to factory settings via ProSave (Page 113)".

If the HMI device starts with the boot splash screen and does not detect the corrupt operating system, the HMI device does **not** switch to maintenance mode. The "Maintenance Mode" dialog is **not** displayed. You must reset the HMI device to the factory settings. In this case, start the HMI device while pressing the "Maintenance" button as described in this section.

NOTICE

The operating system must be updated in maintenance mode

If you start the HMI device while pressing the "Maintenance" button, the HMI device is in maintenance mode. In maintenance mode, the "Maintenance Mode" dialog is displayed. The operating system **must** be updated.

Only start the HMI device while pressing the "Maintenance" button if you are sure that you want to update the operating system.

Procedure

Proceed as follows:

1. Turn off the power supply of the HMI device.
2. Press the "Maintenance" button. Use a blunt, sufficiently sturdy tool made of non-conductive material, diameter approx. 5 mm.

You can find the "Maintenance" button in the opening between the X1 and X61 interfaces.

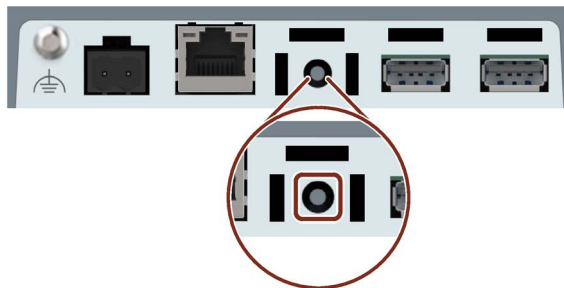

Be sure to hit the button accurately and do not slide the tool off the button.

3. Switch on the power supply of the HMI device and keep the "Maintenance" button pressed until the boot splash screen appears.

The HMI device restarts, the "Maintenance Mode" dialog box is displayed. Connect the HMI device to a configuration PC and reset the HMI device to the factory settings using the ProSave software. Follow the procedure from step 6 in the section "Resetting an HMI device to factory settings via ProSave (Page 113)".

7.4 Spare parts and repairs

Repairs

Contact your Siemens representative (<https://www.siemens.com/aspa>). Filter by expertise, product and region.

Your contact person will let you know if a product can be repaired and how to return it.

Contact your representative before returning a product, including when you would like to request prioritized handling of your repair, a cost estimate, a repair report or an examination report.

The representative can also provide information about spare parts, if available.

Spare parts

Spare parts and accessories for the HMI device can be found in section "Accessories (Page 14)".

7.5 Recycling and disposal

Due to the low levels of pollutants in the HMI devices described in these operating instructions, they can be recycled.

Contact a certified disposal service company for electronic scrap for environmentally sustainable recycling and disposal of your old devices and dispose of the device according to the relevant regulations in your country.

Technical information

8.1 Software license agreements

Open Source Software

Observe the software license agreements for Open Source Software on the supplied "Open Source Software License Conditions" data medium.

8.2 Markings and approvals

Note

Markings and approvals on the rating plate

The following overview provides information about the possible markings and approvals.

Only the markings and approvals specified on the rating plate apply to the device.

CE marking



The devices meet the general and safety-related requirements of the following EU directives and conform with the harmonized European standards (EN) published in the official gazettes of the European Union and confirmed in the EU Declarations of Conformity:

- 2014/30/EU "Electromagnetic Compatibility Directive" (EMC Directive)
- 2011/65/EU "Directive of the European Parliament and of the Council of 8 June 2011 on the restriction of the use of certain hazardous substances in electrical and electronic equipment" (RoHS Directive)

EU Declarations of Conformity

The EU Declarations of Conformity are available to the relevant authorities at the following address:

Siemens Aktiengesellschaft
Digital Industries
Factory Automation
DI FA TI COS
P.O. Box 1963
D-92209 Amberg

You can also find the declarations by entering the article numbers for download on the Internet (<https://support.industry.siemens.com>). Filter the comments for the entry type "Certificates".

UKCA marking



The devices fulfil the general and safety-related requirements of the following regulations and related amendments, and complies with the designated British standards (BS) published in the official consolidated list of the British Government.

- Electromagnetic Compatibility Regulations 2016 (EMC)
- The Restriction of the Use of Certain Hazardous Substances in Electrical and Electronic Equipment Regulations 2012 (RoHS)

UK Declarations of Conformity

The UK Declarations of Conformity are available to the relevant authorities at the following address:

Siemens plc
Princess Road
Manchester
M20 2UR
United Kingdom

You can also find the declarations by entering the article numbers for download on the Internet (<https://support.industry.siemens.com>). Filter the comments for the entry type "Certificates".

UL approval

Observe the following notes:

- The device shall be supplied from an isolating source.
- Only for use in LAN, not for connection to telecommunication circuits.



Underwriters Laboratories Inc. (E116536) in accordance with

- UL 61010-1 and UL 61010-2-201
- CAN/CSA C22.2 No. 61010-1 and 61010-2-201

RCM Australia/New Zealand



This product meets the requirements of EN 61000-6-4 Generic standards – Emission standard for industrial environments.

Korea Certificate



This product conforms to Limit Class A for emission of radio interference. This device is not intended to be used in residential areas.

이 기기는 업무용(A급) 전자파 적합기기로서 판매자 또는 사용자는 이 점을 주의하시기 바라며 가정 외의 지역에서 사용하는 것을 목적으로 합니다.

EAC (Eurasian Conformity)



The EAC (Eurasian Conformity) marking confirms the conformity with the technical regulations (TR) of the Eurasian Economic Union.

WEEE label (European Union)



Disposal instructions, observe the local regulations and the section "Recycling and disposal (Page 118)".

8.3 Certificates

Marine approvals

The following marine approvals are provided for the device:

- ABS (American Bureau of Shipping)
- BV (Bureau Veritas)
- DNV (Det Norske Veritas)
- LRS (Lloyds Register of Shipping)
- Class NK (Nippon Kaiji Kyokai)
- KR (Korean Register of Shipping)
- CCS (China Classification Society)
- RINA (Registro Italiano Navale)

After acceptance you will find the certificates on the Internet (<https://support.industry.siemens.com/cs/ww/en/ps/26033/cert>).

8.4 Standards and requirements

IEC 61131-2

The devices meet the requirements and criteria of IEC 61131-2, Programmable Logic Controllers, Part 2: Operating resource requirements and tests.

IEC 61010-2-201

The devices meet the requirements and criteria of the IEC 61010 standard, Safety Requirements for Electrical Equipment for Measurement, Control, and Laboratory Use - Part 2-201: Special requirements for control equipment.

8.5 Electromagnetic compatibility

The device fulfills, amongst others, the requirements of the EMC directive applicable to the European domestic market.

Installing the device according to EMC directive

EMC-compliant mounting of the device and the use of interference-proof cables provide the basis for interference-free operation.

Observe the following manuals in addition to these operating instructions:

- Designing interference-free controllers
(<https://support.industry.siemens.com/cs/ww/en/view/59193566>)
- Industrial Ethernet/PROFINET – Passive network components
(<https://support.industry.siemens.com/cs/ww/en/view/84922825>)

Pulse-shaped disturbance

The following table shows the electromagnetic compatibility of the modules with regard to pulse-shaped interference. The precondition for electromagnetic compatibility is that the device meets the specifications and guidelines for electrical installation.

Pulse-shaped interference	Tested with	Test level equivalence
Electrostatic discharge in accordance with IEC 61000-4-2	Air discharge: 8 kV	3
	Contact discharge: 6 kV (front)	
	Contact discharge: 4 kV (rear)	2
Bursts (high-speed transient interference) in accordance with IEC 61000-4-4	2 kV supply cable 1 kV signal line, < 30 m	3
	2 kV signal line, > 30 m	4
High-energy single pulse (surge) according to IEC 61000-4-5	Asymmetrical coupling (line to ground):	
	• 1 kV supply cable, DC voltage	2
	• 2 kV signal cable/data cable, > 30 m	3
Coupling process: 42 Ω, 0.5 μF ¹	Symmetrical coupling (line to line):	
	• 0.5 kV power cable, DC voltage	2
	• 1 kV signal line, > 30 m	3

¹ Basically, you must connect the HMI device to your own distribution system (or batteries) via an upstream local power supply. If you connect the HMI device directly to your own distribution system, you must provide additional protective measures against overvoltage.

Sinusoidal interference

The following table shows the EMC behavior of the modules with respect to sinusoidal interference. This requires the device to meet the specifications and directives for electrical installation.

Sinusoidal interference	Test values
HF radiation (electromagnetic fields) according to IEC 61000-4-3	80% amplitude modulation at 1 kHz <ul style="list-style-type: none"> • to 10 V/m from 80 MHz to 1 GHz • to 3 V/m from 1.4 GHz to 6 GHz
HF current feed on cables and cable shields according to IEC 61000-4-6	Test voltage 10 V, with 80% amplitude modulation of 1 kHz in the 150 kHz to 80 MHz range
Magnetic field strength according to IEC 61000-4-8	50/60 Hz; 100 A/m rms

Emission of radio interference

The following table shows the interference emission from electromagnetic fields according to EN/IEC 61000-6-4, measured at the distances listed.

Radiated emission (emitted interference)

Frequency range	Measuring distance	Interference emission
30 MHz to 230 MHz	10 m	< 40 dB ($\mu\text{V/m}$) quasi-peak
230 MHz to 1000 MHz	10 m	< 47 dB ($\mu\text{V/m}$) quasi-peak
1 GHz to 3 GHz	3 m	< 76 dB peak and < 56 dB average
3 GHz to 6 GHz	3 m	< 80 dB peak and < 60 dB average

Emission of radio interference voltages

Frequency range	Interference emission
0.150 MHz to 0.5 MHz	< 89 dB quasi-peak and < 76 dB average
0.5 MHz to 30 MHz	< 83 dB quasi-peak and < 70 dB average

See also

EMC information in section "Notes about usage (Page 20)".

8.6 Mechanical ambient conditions

8.6.1 Transport and storage conditions

The following information is valid for a device that is transported and stored in its original packaging.

Type of condition	Permitted range
Free-fall in product package	≤ 0.3 m
Vibration according to IEC 60068-2-6	5 ... 8.4 Hz, displacement 3.5 mm 8.4 ... 500 Hz, acceleration 1 g
Shock according to IEC 60068-2-27	250 m/s ² , 6 ms, 1000 shocks

8.6.2 Operating conditions

The following information applies to a device installed according to the specifications in these operating instructions.

Type of condition	Permitted range
Vibration according to IEC 60068-2-6	5 ... 8.4 Hz, deflection 3.5 mm 8.4 ... 200 Hz, acceleration 1 g
Shock according to IEC 60068-2-27	150 m/s ² , 11 ms, 3 shocks

Shock pulses within the specified range can be transferred to the display but do not impact the functionality of the device.

8.7 Climatic ambient conditions

8.7.1 Transport and storage conditions

The following information applies to a device that is transported in the original packaging and weather-proof packaging and stored for some time.

Type of condition	Permitted range
Temperature	-20 ... 60 °C
Atmospheric pressure	1140 ... 660 hPa, corresponds to an elevation of -1000 to 3500 m
Relative humidity	10 ... 90 %
Pollutant concentration	According to ANSI/ISA-71.04-2013 severity level G3

Note

If dewing has developed, wait until the HMI device has dried completely before switching it on.

Do not expose the HMI device to direct radiation from a heater.

8.7.2 Operating conditions

The following information applies to a device installed according to the specifications in these operating instructions.

The HMI device is intended for weatherproof and stationary use.

Type of condition	Mounting position	MTP400-1200
Temperature, Mounting in landscape format	Vertical	0 ... 50 °C
	Inclined, maximum inclination 35°	0 ... 40 °C
Temperature, Mounting in portrait format	Vertical	0 ... 40 °C
	Inclined, maximum inclination 35°	0 ... 35 °C
Air pressure ¹ , operation elevation	1140 ... 795 hPa, corresponds to an elevation of -1000 to 2000 m	
Relative humidity	From 10 ... 90%, no condensation at the rear of the device	
Pollutant concentration	According to ANSI/ISA-71.04-2013 severity level G3	

¹ No pressure difference is allowed inside and outside the enclosure / control cabinet

Observe the Notes on use (Page 20) and section "Permitted mounting positions (Page 23)".

Also observe the climate diagram in the following section.

Note

The system components connected to the HMI device, the power supply for example, must also be suited to the respective operating conditions.

8.7.3 Climate diagram

The diagram below shows the range for temperature and humidity during continuous operation.

The information applies to a device installed in landscape format without inclination.

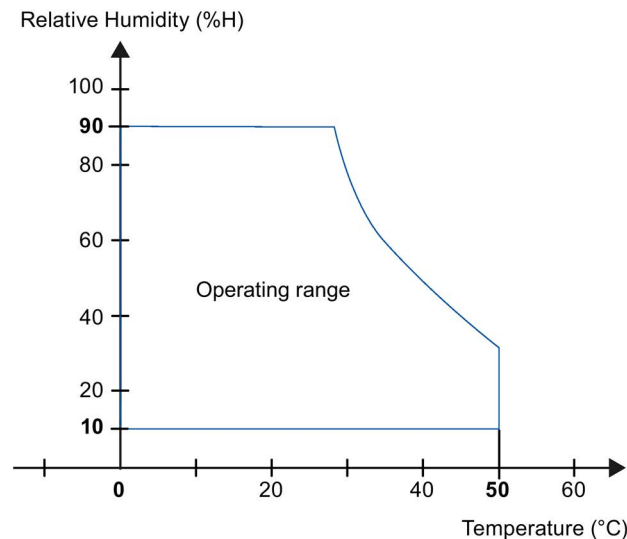

8.8 Information on insulation tests, protection class and degree of protection

Insulation test

The insulation strength is demonstrated in the type test with the following test voltages in accordance with IEC 61010-2-201:

Circuit	Insulation tested with (type test)
Rated voltage U_e 24 V	707 V DC to other circuits / to ground
Ethernet connector	2250 V DC

Degree of pollution

The device meets the following requirements according to IEC 61010-2-201:

Device side	Degree of pollution
Front	3
Rear	2

Overvoltage category

Overvoltage category II according to IEC 61010-2-201.

Protection class

Protection class III according to IEC 61010-2-201.

Protection against foreign objects and water

The device meets the requirements according to IEC 60529 and UL50E.

Device side	Degree of protection
Front	When mounted: <ul style="list-style-type: none"> IP65 according to IEC 60529 Type 4X/12 (indoor use only, front face only) according to UL50E
Rear	IP20 Protection against contact with standard test probes. There is no protection against the ingress of water, dust and noxious gas.

The degree of protection at the front can only be guaranteed if the mounting seal lies flush against the mounting cutout. Observe the corresponding information in section "Preparing the mounting cutout (Page 26)".

8.9 Dimension drawings

8.9.1 Dimension drawings of the MTP400 Unified Basic

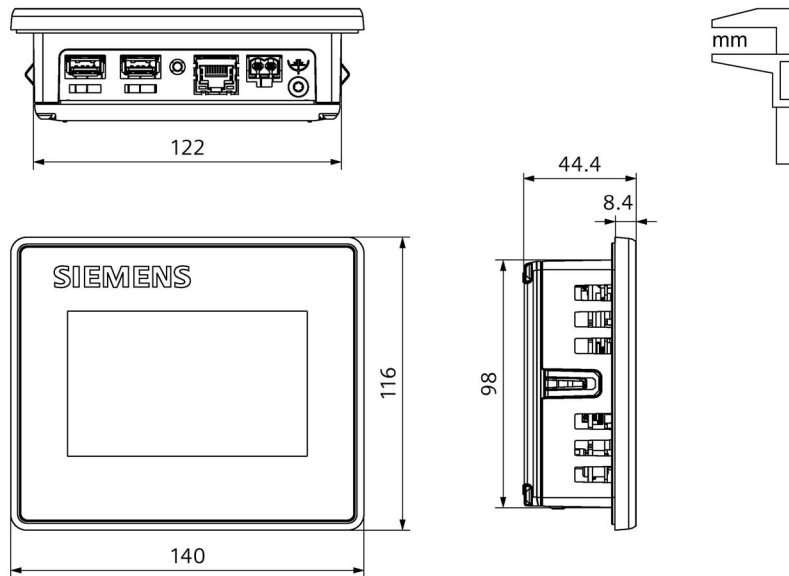

8.9.2 Dimension drawings of the MTP700 Unified Basic

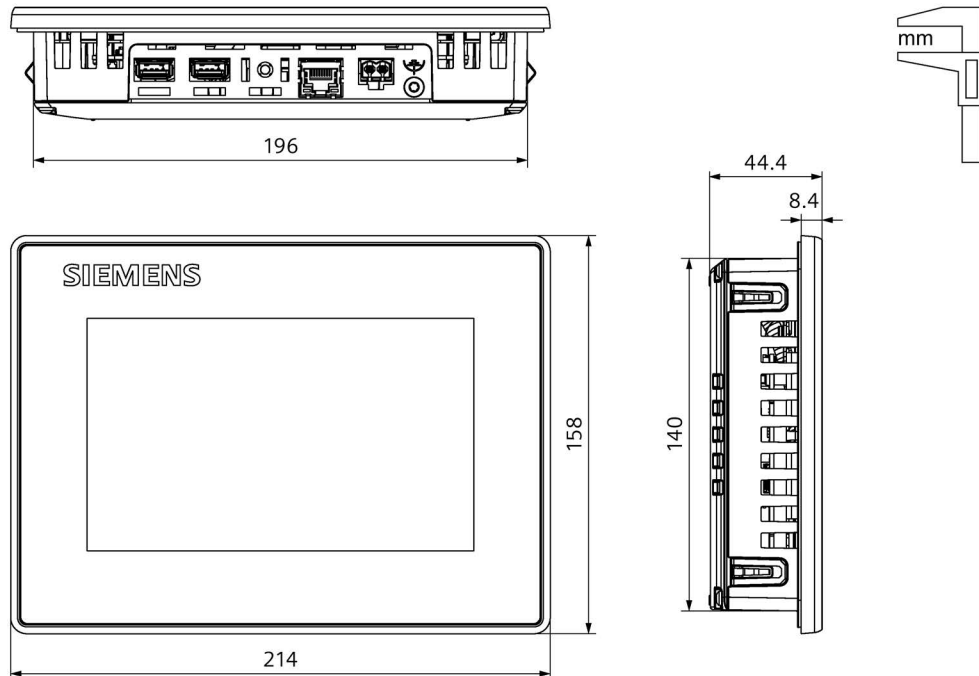

8.9.3 Dimension drawings of the MTP1000 Unified Basic

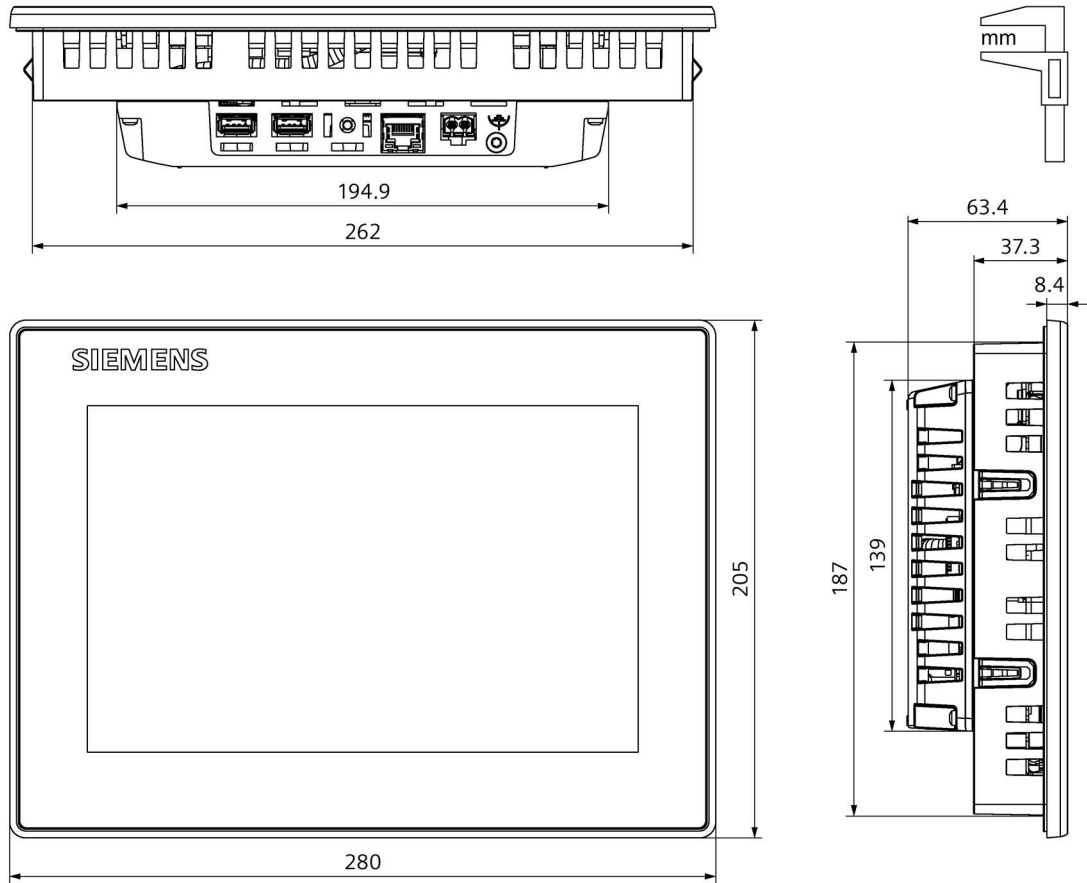

8.9.4 Dimension drawings of the MTP1200 Unified Basic

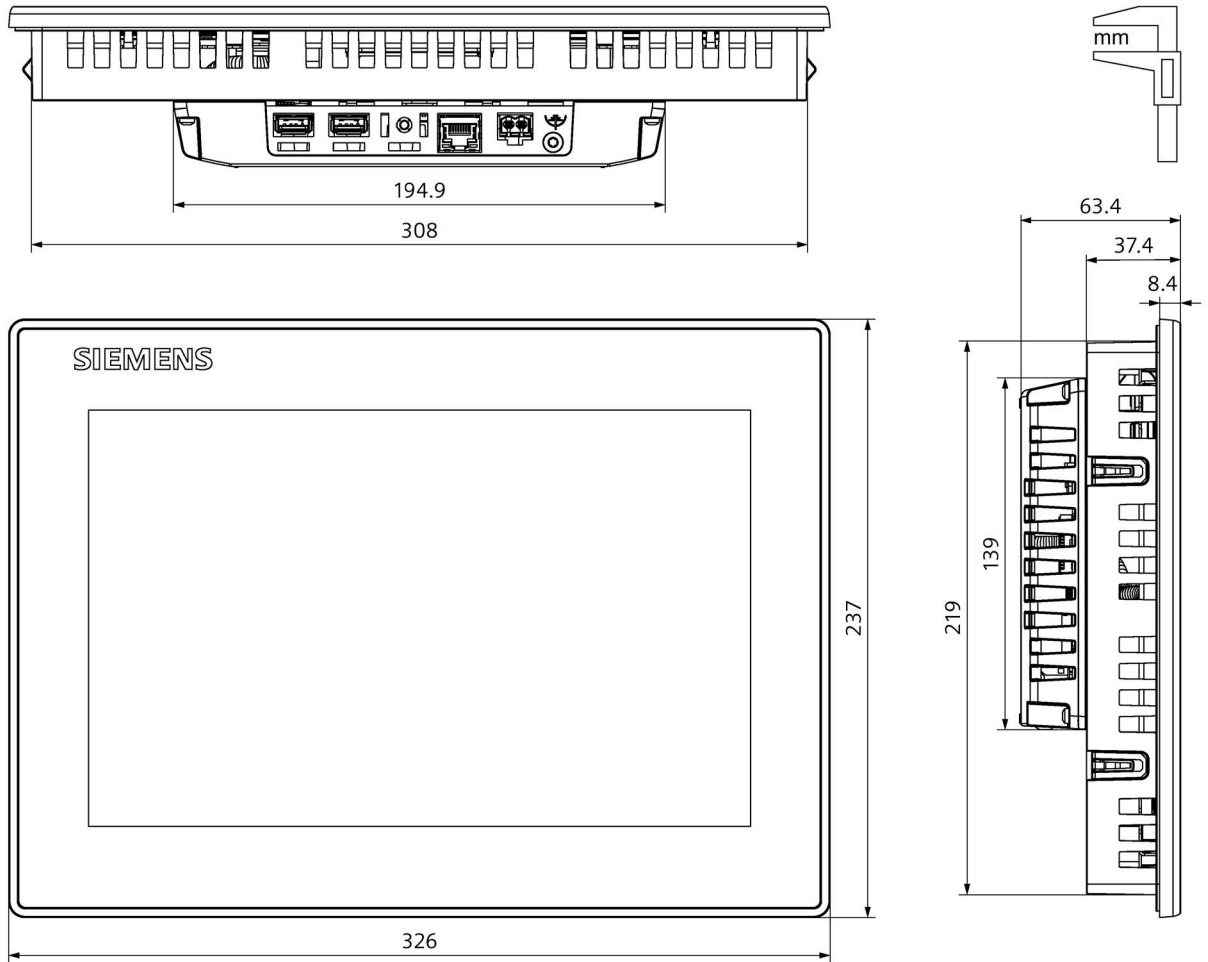

8.10 Technical specifications

8.10.1 MTP400, MTP700 Unified Basic

Weight

Unified Basic HMI device	MTP400	MTP700
Weight without packaging	0.45 kg	0.85 kg

Display

Unified Basic HMI device	MTP400	MTP700
Type	LCD TFT	
Display diagonal	4.3"	7.0"
Active display area	93.6 x 56.2 mm	152.4 x 91.4 mm
Resolution/pixels	800 x 480	
Possible colors	Up to 16.7 million	
Brightness control via Control Panel, value range	10 ... 100%	
Brightness control via WinCC, value range	0 ... 100%, values below 10% are set to 10%	
Backlight	LED	
Half Brightness Life Time (MTBF ¹)	20000 h	
Pixel error class in accordance with ISO 9241-307	I	

¹ MTBF: Operating hours after which the maximum brightness is reduced by half compared to the original value. MTBF is increased by using the integrated dimming function, for example, time-controlled via screensaver or centrally via PROFInergy.

Input device

Unified Basic HMI device	MTP400	MTP700
Multi-touch screen (capacitive)	Yes	

Memory

Unified Basic HMI device	MTP400	MTP700
Random access memory	2 GB LPDDR4-SDRAM	
Internal flash memory	10 GB eMMC pSLC	
Usable memory for application data	256 MB	
Internal parameter set memory ¹	10 MB	

¹ Expansion via USB flash drive on interface X61 or X62

Interfaces

Unified Basic HMI device	MTP400	MTP700
PROFINET (LAN)	1 x RJ45 10/100/1000 Mbps	
USB 2.0 (Type A)	2 x Host ¹	

¹ USB type A; maximum load per interface: 500 mA; maximum total load of all interfaces: 1 A

Power supply

Unified Basic HMI device	MTP400	MTP700
Rated voltage	24 V DC	
Permitted voltage range	+19.2 V ... +28.8 V	
Mains and voltage buffering time	20 ms, corresponds to PS2 according to IEC 61131-2	
Rated current (typical) at rated voltage, without loads ¹	0.16 A	0.20 A
Current consumption (min. to max.) at nominal voltage, load-dependent	0.14 ... 0.47 A	0.16 ... 0.51 A
Maximum current consumption at +19.2 V	0.63 A	0.69 A
Power consumption (typical) at rated current and rated voltage ²	7.1 W	8.2 W
Inrush current I ² t at rated voltage	0.45 A ² s	0.36 A ² s
Maximum permitted transient	35 V (500 ms)	
Minimum time between two transients	50 s	
Internal protection	Electronic	

¹ No load on the USB interfaces, display brightness 70%

² The power loss generally corresponds to the specified value for power consumption.

Miscellaneous

Unified Basic HMI device	MTP400	MTP700
Buffered real-time clock ¹	Yes	

¹ Buffering time typically 6 weeks

8.10.2 MTP1000, MTP1200 Unified Basic

Weight

Unified Basic HMI device	MTP1000	MTP1200
Weight without packaging	1.55 kg	2.10 kg

Display

Unified Basic HMI device	MTP1000	MTP1200
Type	LCD TFT	
Display diagonal	10.1"	12.1"
Active display area	217.0 x 135.6 mm	261.1 x 163.2 mm
Resolution/pixels	1280 x 800	
Possible colors	Up to 16.7 million	
Brightness control via Control Panel, value range	10 ... 100%	
Brightness control via WinCC, value range	0 ... 100%, values below 10% are set to 10%	
Backlight	LED	
Half Brightness Life Time (MTBF ¹)	20000 h	
Pixel error class in accordance with ISO 9241-307	I	

- ¹ MTBF: Operating hours after which the maximum brightness is reduced by half compared to the original value. MTBF is increased by using the integrated dimming function, for example, time-controlled via screensaver or centrally via PROFIenergy.

Input device

Unified Basic HMI device	MTP1000	MTP1200
Multi-touch screen (capacitive)	Yes	

Memory

Unified Basic HMI device	MTP1000	MTP1200
Random access memory	2 GB LPDDR4-SDRAM	
Internal flash memory	10 GB eMMC pSLC	
Usable memory for application data	256 MB	
Internal parameter set memory ¹	10 MB	

- ¹ Expansion via USB flash drive on interface X61 or X62

Interfaces

Unified Basic HMI device	MTP1000	MTP1200
PROFINET (LAN)	1 x RJ45 10/100/1000 Mbps	
USB 2.0 (Type A)	2 x Host ¹	

¹ USB type A; maximum load per interface: 500 mA; maximum total load of all interfaces: 1 A

Power supply

Unified Basic HMI device	MTP1000	MTP1200
Rated voltage	24 V DC	
Permitted voltage range	+19.2 V ... +28.8 V	
Mains and voltage buffering time	20 ms, corresponds to PS2 according to IEC 61131-2	
Rated current (typical) at rated voltage, without loads ¹	0.28 A	0.29 A
Current consumption (min. to max.) at nominal voltage, load-dependent	0.20 ... 0.60 A	0.24 ... 0.67 A
Maximum current consumption at +19.2 V	0.8 A	0.92 A
Power consumption (typical) at rated current and rated voltage ²	9.3 W	11.1 W
Inrush current I ² t at rated voltage	0.36 A ² s	0.36 A ² s
Maximum permitted transient	35 V (500 ms)	
Minimum time between two transients	50 s	
Internal protection	Electronic	

¹ No load on the USB interfaces, display brightness 70%

² The power loss generally corresponds to the specified value for power consumption.

Miscellaneous

Unified Basic HMI device	MTP1000	MTP1200
Buffered real-time clock ¹	Yes	

¹ Buffering time typically 6 weeks

8.11 Description of the interfaces

8.11.1 DC24V X80

Power supply 24 V DC 2-pin

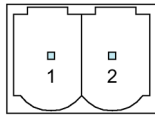

Pin	Meaning
1	+24 V DC
2	Ground

8.11.2 PROFINET (LAN) X1

PROFINET (LAN) 10/100/1000 Mbps, RJ45 socket

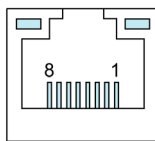

Pin	Name	Meaning
1	D1+	Bi-directional data 1+
2	D1-	Bi-directional data 1-
3	D2+	Bi-directional data 2+
4	D3+	Bi-directional data 3+
5	D3-	Bi-directional data 3-
6	D2-	Bi-directional data 2-
7	D4+	Bi-directional data 4+
8	D4-	Bi-directional data 4-

8.11.3 USB X61/X62

USB Type A

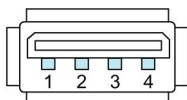

Pin	Name	Meaning
1	VBUS	+5 V, fused
2	D-	Data channel, bidirectional
3	D+	Data channel, bidirectional
4	GND	Ground

8.12 Communication with controllers

Number of connections

The Unified Basic Panels support a maximum of 8 connections to S7 controllers.

Controllers

The following controllers and communication drivers are supported by the HMI devices:

- SIMATIC S7-1200/1500
- SIMATIC S7-300/400
- OPC UA client
- Allen Bradley Ethernet/IP
- Mitsubishi iQR/iQF
- Mitsubishi MC TCP/IP
- OMRON Ethernet/IP
- Standard Modbus TCP/IP

Additional CSPs can be downloaded from the Internet (<https://support.industry.siemens.com/cs/ww/en/view/109739698>). Observe the documentation in the respective download.

Using Secure HMI Communication

The HMI devices support Secure HMI Communication in conjunction with a controller that also supports Secure HMI Communication.

You can find detailed information on Secure HMI Communication in the:

- TIA Portal help under "Editing devices and networks > Configuring devices and networks > Configuring networks > Secure communication"
- In the TIA Portal Help via a search for "Secure communication and certificates (RT Unified)"
- S7-1500, ET200 Communication Manual (<https://support.industry.siemens.com/cs/ww/en/view/59192925>)

The following sections describe the most important steps to use Secure HMI Communication on the HMI device.

Configuring Secure HMI communication

1. Configure the HMI device with an alarm control.

Note

You cannot detect errors when establishing a connection without the alarm control.

2. Configure the CPU with the necessary security settings. Select a PLC communication certificate to secure the HMI connection or have a PLC communication certificate generated by the TIA Portal.
3. Configure the HMI connection between CPU and HMI device.
4. Load the project onto the CPU and the HMI device. During the project transfer, the PLC communication certificate and if necessary a required CA certificate (certification authority) as well is transferred to the CPU and to the HMI device.

Note

Updating and loading the CPU configuration requires a new download to the HMI device

If the configuration of the CPU is changed and downloaded to the controller, the PLC communication certificate of the controller is updated. In this case, the PLC communication certificate of the HMI device must also be updated by means of a new project download.

Trusting the PLC communication certificate

During the connection setup, the CPU transfers the PLC communication certificate to the HMI device. Distinguish between the following cases:

- If the PLC communication certificate on the HMI device already has the "trusted" status, Secure HMI Communication between CPU and HMI device is automatically established.
- If the PLC communication certificate on the HMI device is not yet available with "trusted" status, the alarm control of the HMI device shows an alarm indicating that the CPU is not trusted along with an error code.

In this case, you have to mark the PLC communication certificate on the HMI device as "trusted".

To mark the PLC communication certificate as "trusted", do the following.

1. Open the Control Panel.
2. Select "Security > Certificates".
3. Select the entry "Other Certificates" from the "Certificate store" drop-down list.
4. Select the PLC communication certificate of the CPU in the "Other certificates" list.
5. Press the "Trust" button.
6. Start the HMI runtime software again.

If the PLC communication certificate on the HMI device has the "trusted" status, Secure HMI Communication can be established.

See also

Certificates (Page 83)

8.13 Scope of functions with WinCC

Performance features

The following tables of performance features help you to assess whether your project conforms to the system limits of an HMI device.

The specified maximum values are not additive. It cannot be guaranteed that configurations running on the devices at the full system limits will be functional.

In addition, the complexity of configuring the images, such as number of objects per screen, number of tag connections, cycle times and scripts, has a decisive influence on the image opening times and the performance in runtime.

In addition to the specified limits, observe the restrictions imposed by configuration memory resources.

You can find more information on the performance features in the TIA Portal Help under "Visualizing processes (RT Unified) > Performance features > SIMATIC Unified Basic Panel".

Tags

Unified Basic HMI device	Display diagonal 4" to 12"
Number of tags in the project	1000
Number of elements per array	100

Alarms

Unified Basic HMI device	Display diagonal 4" to 12"
Number of alarm classes	32
Number of discrete alarms	2000
Number of analog alarms	100
Length of an alarm in characters	512
Number of alarm texts per interrupt	10
Number of process values per alarm	10
Number of queued alarm events	64
Size of the alarm buffer ¹	2000

¹ Corresponds to the number of all states of the alarms of all configured alarm classes and also includes the alarms of alarm classes that are not displayed in an alarm control due to the configuration.

Note

Alarm buffer

If too many alarms are written to the alarm buffer in short time intervals, the life of the internal memory and thus the service life of the HMI device will be reduced.

Configure an alarm window, and check the number and frequency of the alarms that occur. Adjust the configuration accordingly if you expect a permanent load on the internal memory from alarms.

If the alarms do not have to be stored permanently, you can disable the retentivity of the alarm buffer, see section "Alarm persistency (Page 71)".

In addition, you can activate the monitoring of the internal flash memory, see section "Performance (Page 69)".

Screens

	Unified Basic HMI device	Display diagonal 4" to 12"
Number of screens		300
Number of basic objects per screen		600
Number of objects from the "Controls" area per screen		5
Number of tags per screen		300

Parameter sets

	Unified Basic HMI device	Display diagonal 4" to 12"
Number of parameter set types		250
Number of parameter sets per parameter set type		250
Number of entries per parameter set		250
Reserved memory for parameter sets in the internal flash ¹		5 MB

¹ Expansion via USB flash drive on interface X61 or X62

Logs

	Unified Basic HMI device	Display diagonal 4" to 12"
Number of logs		10
Number of logging tags		50
Number of entries per log		50000

Trends

	Unified Basic HMI device	Display diagonal 4" to 12"
Number of trends		50
Number of trends per trend view		5
Number of trend areas per trend view		2

Text lists and graphics lists

Unified Basic HMI device	Display diagonal 4" to 12"
Number of graphics lists	100
Number of text lists	300
Number of entries per text or graphics list	250
Number of graphic objects	1000

Scripts

Unified Basic HMI device	Display diagonal 4" to 12"
Number of Java scripts	50

Scheduler

Unified Basic HMI device	Display diagonal 4" to 12"
Number of tasks, time- or event-triggered	10

Communication

Unified Basic HMI device	Display diagonal 4" to 12"
Number of S7 connections	8

Languages

Unified Basic HMI device	Display diagonal 4" to 12"
Number of runtime languages	32

User administration

Unified Basic HMI device	Display diagonal 4" to 12"
Number of roles	50
Number of predefined function rights	20
Number of users	200

Project

Unified Basic HMI device	Display diagonal 4" to 12"
Size of the project files on the device	< 50 MB

Technical Support

A.1 Service and support

You can find additional information and support for the products described on the Internet at the following addresses:

- Technical support (<https://support.industry.siemens.com>)
- Support request form (<https://www.siemens.com/supportrequest>)
- After Sales Information System SIMATIC IPC/PG (<https://www.siemens.com/asis>)
- SIMATIC Documentation Collection (<https://www.siemens.com/simatic-tech-doku-portal>)
- Your local representative (https://www.automation.siemens.com/aspa_app)
- Training center (<https://siemens.com/sitrain>)
- Industry Mall (<https://mall.industry.siemens.com>)
- TIA Selection Tool (<https://www.siemens.com/tia-selection-tool>)

When contacting your local representative or Technical Support, please have the following information at hand:

- MLFB of the device
- BIOS version for industrial PC or image version of the device
- Other installed hardware
- Other installed software

Firmware and software

Firmware and software for your HMI device are constantly being further developed. Check regularly whether software updates or patches are available for your HMI device and install the latest versions.

You can find the latest updates and patches for your HMI device on the Internet at the following addresses:

- HMI Panel Firmware (<https://support.industry.siemens.com/cs/ww/en/view/109746530>)
- WinCC (TIA Portal) Downloads (<https://support.industry.siemens.com/cs/ww/en/ps/24212/dl>)

Current documentation

Always use the current documentation available for your product. You can find the latest edition of this manual and other important documents by entering the article number of your device on the Internet (<https://support.industry.siemens.com>). If necessary, filter the entries by entry type "Manual".

A.2 System alarms

System alarms on the HMI device provide information about internal states of the HMI device and the controller.

Note

System alarms are only displayed if an alarm window was configured. System alarms are output in the language currently set on your HMI device.

System alarm parameters

System alarms may contain encrypted parameters which are relevant to troubleshooting because they provide a reference to the source code of the runtime software. These parameters are output after the text "Error code:".

Description of the system alarms

You can find a list of all system events for your HMI device in the TIA Portal Help.

A.3 Information about the manufacturer

The manufacturer of the HMI devices described in this document is Siemens Aktiengesellschaft.











The manufacturer address is:





Siemens Aktiengesellschaft
Digital Industries
Postfach 48 48
90026 NÜRNBERG
GERMANY

Markings and symbols

B.1 Safety-relevant symbols

The following table describes symbols that can be added to your SIMATIC device, to its packaging or to an enclosed document in addition to the symbols described in the manuals.

Symbol	Meaning	Reference
	General danger sign Caution / Attention You must following the operating instructions. The operating instructions contain information on the type of the potential hazard and enable you to identify risks and implement countermeasures.	ISO 7000 No. 0434B, DIN ISO 7000 No. 0434B
  ONLY EX MODULES	Attention, only relevant for modules with Ex approval	
	Follow the instructions	ISO 7010 M002
	May be installed by qualified electricians only	IEC 60417 No. 6182
 F<2N DISPLAY F<4N HOUSING	Mechanical load for HMI devices	
 CABLE SPEC.	Connection cables must be designed for the ambient temperature	
 EMC	EMC-compliant installation	
 U = 0V	No mounting or pulling & plugging under voltage	
 230V MODULES	Dangerous electrical voltage for 230V modules	ANSI Z535.2
 24V MODULES	Protection class III, supply only with protective low voltage (SELV/PELV)	IEC 60417-1-5180 "Class III equipment"

Symbol	Meaning	Reference
 <p>INDOOR USE ONLY INDUSTRIAL USE ONLY</p>	Only for industrial applications and indoor areas (control cabinet)	
	Device is to be integrated or installed in a control cabinet	
 <p>ZONE 2 USE CABINET IP54</p>	Integrate or install devices approved for Ex Zone 2 in a control cabinet with at least IP54	
 <p>ZONE 22 USE CABINET IP6x</p>	Integrate or install devices approved for Ex Zone 22 in a control cabinet with at least IP6x	

Abbreviations

C

ANSI	American National Standards Institution
CA	Certificate Authority
CER	Internet security Certificate
CPU	Central Processing Unit
CRL	Certificate Revocation List
CSP	Communication Service Package
DC	Direct Current
DHCP	Dynamic Host Configuration Protocol
DNS	Domain Name System
DP	Distributed I/O
ESD	Components and modules endangered by electrostatic discharge
EMC	Electromagnetic Compatibility
EN	European standard
GND	Ground
HF	High Frequency
HMI	Human Machine Interface
HSP	Hardware Support Package
IEC	International Electronic Commission
IP	Internet Protocol (in relation to Internet addresses)
IP	Ingress Protection (in relation to degrees of protection)
ISO	International Standard Organisation
LAN	Local Area Network
LED	Light Emitting Diode
MAC	Media Access Control
MTBF	Mean Time Between Failures
n. c.	not connected
PC	Personal Computer
PG	Programming device
RAM	Random Access Memory
PELV	Protective Extra Low Voltage
RJ	Registered Jack
SELV	Safety Extra Low Voltage
TCP/IP	Transmission Control Protocol/Internet Protocol
TIA	Totally Integrated Automation
TFT	Thin Film Transistor
UMAC	User Management and Access Control
UMC	User Management Component
USB	Universal Serial Bus

Glossary

Alarm

An alarm may be a system alarm or a user-defined alarm. A user-defined alarm typically indicates a particular operating state of the plant, a system alarm typically contains information about the state of the HMI device.

Boot loader

The bootloader is used to start the operating system and is started automatically after the power on of the HMI device power. The Control Panel opens after the operating system has loaded. The bootloader can be updated by qualified Siemens Aktiengesellschaft personnel.

Configuration PC

A configuration PC is a programming device or PC on which plant projects are created using engineering software.

Configuration software

Configuration software is used to create projects used for the purpose of process visualization. WinCC represents such configuration software, for example.

Controller

Controller is a general term for devices and systems with which the HMI device communicates, for example SIMATIC S7.

Degree of protection

The degree of protection specifies a standard of electronic equipment for a variety of ambient conditions – and the protection of humans against potential danger when using this equipment.

The degree of protection classified by IP differs from the protection class. But both involve protection against touching dangerous electric voltage. The IP degree of protection also classifies the protection of equipment against dirt and moisture.

Display duration

The display duration defines whether and for how long a message or a dialog box is displayed on the HMI device.

EMC

Electromagnetic compatibility (EMC) refers to a usually desirable state, in which technical equipment does not disturb one another with unwanted electrical or electromagnetic effects. Electromagnetic compatibility deals with technical and regulatory questions of undesired, mutual influence in electrical engineering.

Event

Functions are triggered by defined incoming events. Events can be configured. Events which can be assigned to a button include "Press" and "Release", for example.

Field

Area reserved in configured screens for the input and output of values.

Flash memory

Flash memory is a non-volatile memory with EEPROM chips that is implemented either as mobile storage medium, or as permanently installed memory module on the motherboard.

Half Brightness Life Time

Time period after which brightness is reduced to 50% of the original value. The specified value depends on the operating temperature.

HMI device

An HMI device is a device used for the operation and monitoring of machines and plants. The machine or plant states are visualized on the HMI device by means of graphic objects. The operator controls of the HMI device allow the operator to interact with the processes of the machine or plant.

HMI device image

The HMI device image is a file that can be transferred from the configuration PC or from an external storage medium to the HMI device. The HMI device image contains the operating system for the HMI device and the elements of the runtime software which are required to start and visualize the project file.

Input box

Use the input box to enter characters and values that are stored in the HMI device or transferred to the controller.

Object

An object is a project element such as a screen or an alarm. Objects are used to view or enter texts and values on the HMI device.

Operating element

An operating element is a component of a project used to enter values and trigger functions. A button, for example, is an operating element.

Parameter set

A parameter set is a combination of tags forming a fixed data structure. The configured data structure can be assigned data in the configuration software or on the HMI device and is then referred to as a record. The use of parameter sets ensures that all data assigned to a data record is transferred synchronously to the controller.

Plant

General term referring to machines, processing centers, systems and processes which are operated and monitored on an HMI device.

Process visualization

Process visualization is the representation of technical processes by means of text and graphic elements. Configured plant screens allow the operator to use input and output information to intervene in active plant processes.

Project

A project contains information on the visualization of the automation process and is created using a configuration software. The project normally contains several screens with embedded plant-specific objects, basic settings and alarms. A project configured with WinCC is saved in a file with extension "*.ap1x", where "x" stands for the version key. Example: "MyProject.ap18" for a WinCC V18 project.

Protection class

The protection class is used in electrical engineering to classify and identify electrical equipment in relation to existing safety measures designed to prevent electric shock. There are three protection classes for electrical equipment.

Runtime software

A project is started and visualized on the HMI device via the runtime software.

Screen

A screen is a form of visualization for all logically related process data in a plant. The representation of the process data can be visually supported by graphic objects.

Screen object

A screen object refers to objects such as rectangles, input boxes or alarm controls which are configured for visualization or operation of the plant.

Tag

A tag is a defined memory location to which values can be written and from which values can be read. This can be done from the controller or the HMI device. We distinguish between external tags (process tags) and internal tags, depending on whether or not the tag is interconnected with the controller.

Trade goods

In addition to its own accessories, Siemens Aktiengesellschaft also provides high-quality accessories of renowned manufacturers as trade goods. Trade goods are qualified in a brief power-up test but do not undergo a system test by Siemens Aktiengesellschaft. The technical properties of trade goods can deviate from the guaranteed properties of comparable products of Siemens Aktiengesellschaft. Trade goods are identified as such in the online catalog of Siemens Aktiengesellschaft. Technical specifications, drivers, certificates, test verification documents, etc. are supplied by the respective manufacturer to Siemens Aktiengesellschaft and are also available for download in the online catalog or technical support of Siemens Aktiengesellschaft.

Transfer

In "Transfer" mode, data is transferred from a configuration PC to the HMI device.

WinCC

WinCC (TIA Portal) is an engineering software for configuring SIMATIC HMI devices.