

Flow Measurement

SITRANS FM (electromagnetic)

Flow sensors / SITRANS FM MAG 5100 W

Overview



The SITRANS FM MAG 5100 W is an electromagnetic flow sensor designed to meet ground water, drinking water, wastewater, sewage or sludge applications.

Benefits

- DN 15 to DN 2000 (½" to 80")
- Stock program of MAG 5100 W secures short delivery time
- Connection flanges EN 1092-1 (DIN 2501), ANSI, AWWA, AS and JIS
- NBR Hard Rubber and Ebonite Hard Rubber liner for all water applications
- EPDM liner with drinking water approvals
- Hastelloy integrated grounding and measuring electrodes
- Increased low flow accuracy for water leak detection, due to coned liner design
- Drinking water approvals
- Suitable for direct burial and constant flooding
- Custody transfer approvals for cold water and energy metering (MI-001, KIWA, NMI M10, PTB K7.2)
- Built-in length according to ISO 20456; the standard includes sizes up to DN 400
- Easy commissioning, SENSORPROM unit automatically uploads calibration values and settings
- Designed to allow patented in-situ verification using SENSORPROM fingerprint
- Qualified for operation in non-optimal installation conditions with no straight inlet and outlet run of piping (0 × DN)
- Conform to ISO 4064 and EN 14154 for mechanical flowmeters
- FM Fire Service Meter (Class Number 1044) for automatic fire protection systems
- Meets EEC directives: PED 2014/68/EU pressure directive for EN 1092-1 flanges
- Simple onsite or factory upgrade to IP68/NEMA 6P of a standard sensor
- Type approval of marine equipment (DNV)

Application

The main applications of the SITRANS FM electromagnetic flow sensors can be found in the following fields:

- Water abstraction
- Water treatment
- Water distribution network (leak detection management)
- Custody transfer water meters
- Irrigation
- Waste water treatment
- Filtration plant (e.g. reverse osmosis and ultra-filtration)
- Industrial water applications

Mode of operation

The flow measuring principle is based on Faradays law of electromagnetic induction according to which the sensor converts the flow into an electrical voltage proportional to the velocity of the flow.

Integration

The complete flowmeter consists of a flow sensor and an associated transmitter SITRANS FM MAG 5000, MAG 6000 or MAG 6000 I.

The flexible communication concept USM II simplifies integration and update to a variety of fieldbus systems, e.g. HART, DeviceNet, PROFIBUS DP and PA, FOUNDATION Fieldbus H1 or Modbus RTU/RS 485.

Selection and ordering data

Sensor SITRANS FM MAG 5100 W	Article No. 7ME6520-	Order code
Click on the Article No. for the online configuration in the PIA Life Cycle Portal.		
Diameter	● ● ● ● ● - 2 ● ● ● ● ● ● ● ●	
DN 15 (1/2")	1	V
DN 25 (1")	2	D
DN 40 (1 1/2")	2	R
DN 50 (2")	2	Y
DN 65 (2 1/2")	3	F
DN 80 (3")	3	M
DN 100 (4")	3	T
DN 125 (5")	4	B
DN 150 (6")	4	H
DN 200 (8")	4	P
DN 250 (10")	4	V
DN 300 (12")	5	D
DN 350 (14")	5	K
DN 400 (16")	5	R
DN 450 (18")	5	Y
DN 500 (20")	6	F
DN 600 (24")	6	P
DN 700 (28")	6	Y
DN 750 (30")	7	D
DN 800 (32")	7	H
DN 900 (36")	7	M
DN 1000 (40")	7	R
DN 1050 (42")	7	U
DN 1100 (44")	7	V
DN 1200 (48")	8	B
DN 1400 (54")	8	F
DN 1500 (60")	8	K
DN 1600 (66")	8	P
DN 1800 (72")	8	T
DN 2000 (80")	8	Y
Flange norm and pressure rating		
EN 1092-1		
PN 6 DN 1400 ... 2000 (54" ... 80")		A
PN 10 (DN 200 ... 2000 (8" ... 80"))		B
PN 16 (DN 50 ... 1200 (2" ... 48"))		C
PN 16, non PED (DN 700 ... 1200 (28" ... 48"))		D
PN 40 (DN 15 ... 40 (1/2" ... 1 1/2"))		F
ANSI B16.5		
Class 150 (1/2" ... 24")		J
AWWA C-207		
Class D (28" ... 80")		L
AS 4087		
PN 16 (DN 50 ... 1200 (2" ... 48"))		N
JIS		
B 2220:2004 K10 (1" ... 24")		R
Flange material and coating		
Carbon steel flanges ASTM A 105, corrosion-resistant coating of category C4		1
Carbon steel flanges ASTM A 105, 300 µm corrosion-resistant coating of category C5		4
Liner material		
EPDM		2
NBR		3
Transmitter		
Sensor for remote transmitter (order transmitter separately)		A
MAG 6000 I, Aluminum, 18 ... 90 V DC, 115 ... 230 V AC, FM / CSA Class I Div. 2		C

Flow Measurement

SITRANS FM (electromagnetic)

Flow sensors / SITRANS FM MAG 5100 W

Selection and ordering data (continued)

Sensor SITRANS FM MAG 5100 W	Article No. 7ME6520-	Order code
MAG 6000 I, Aluminum, 18 ... 90 V DC, 115 ... 230 V AC (non-Ex)	● ● ● ● ● - 2 ● ● ● ● ● ● ● ●	F
MAG 6000, Polyamid, 11 ... 30 V DC/11 ... 24 V AC		H
MAG 6000, Polyamid, 115 ... 230 V AC		J
MAG 5000, Polyamid, 11 ... 30 V DC/11 ... 24 V AC		K
MAG 5000, Polyamid, 115 ... 230 V AC		L
MAG 6000 CT, Polyamid, 115 ... 230 V AC		M
MAG 6000 CT, Polyamid, 11 ... 30 V DC/11 ... 24 V AC		R
MAG 5000 CT, Polyamid, 115 ... 230 V AC		S
MAG 5000 CT, Polyamid, 11 ... 30 V DC/11 ... 24 V AC		T
<u>Transmitter including wall-mounting kit for remote design</u>		
MAG 5000, Polyamid, 115 ... 230 V AC, incl. special wall-mounting unit (approved marine equipment)		
• M20×1.5 cable glands		Z P 0 C
• ½" NPT cable glands		Z P 0 D
MAG 6000, Polyamid, 115 ... 230 V AC, incl. special wall-mounting unit (approved marine equipment)		
• M20×1.5 cable glands		Z P 0 G
• ½" NPT cable glands		Z P 0 H
MAG 6000 CT, Polyamid, 11 ... 30 V DC/11 ... 24 V AC, incl. wall-mounting unit		
• M20×1.5 cable glands		Z P 0 J
• ½" NPT cable glands		Z P 0 K
MAG 6000 CT, Polyamid, 115 ... 230 V AC, incl. wall-mounting unit		
• M20×1.5 cable glands		Z P 0 L
• ½" NPT cable glands		Z P 0 M
MAG 5000 CT, Polyamid, 11 ... 30 V DC/11 ... 24 V AC, incl. wall-mounting unit		
• M20×1.5 cable glands		Z P 0 N
• ½" NPT cable glands		Z P 0 P
MAG 5000 CT, Polyamid, 115 ... 230 V AC, incl. wall-mounting unit		
• M20×1.5 cable glands		Z P 0 Q
• ½" NPT cable glands		Z P 0 R
Communication		
None		A
HART		B
PROFIBUS PA Profile 3 (only MAG 6000/ MAG 6000 I)		F
PROFIBUS DP Profile 3 (only MAG 6000/ MAG 6000 I)		G
Modbus RTU/RS 485 (only MAG 6000/ MAG 6000 I)		E
FOUNDATION Fieldbus H1 (only MAG 6000/ MAG 6000 I)		J
Cable glands/terminal box		
Metric: Polyamide terminal box or MAG 6000 I compact		1
½" NPT: Polyamide terminal box or MAG 6000 I compact		2

	Order code
Additional information	
Please add "-Z" to Article No. and specify Order code(s) and plain text.	
Certificates	
Pressure test certificate according to EN 10204-3.1	C01
Material certificate according to EN 10204-3.1	C12
Factory certificate according to EN 10204-2.2	C14
Factory certificate according to EN 10204-2.1	C15
Special calibration	
5-point calibration for DN 15 ... 200 ¹⁾	D01
5-point calibration for DN 250 ... 600 ¹⁾	D02

	Order code
5-point calibration for DN 700 ... 1200 ¹⁾	D03
10-point calibration for DN 15 ... 200 ²⁾	D06
10-point calibration for DN 250 ... 600 ²⁾	D07
10-point calibration for DN 700 ... 1200 ²⁾	D08
Default (2 × 25 % and 2 × 90 %) matched-pair calibration for DN 15 ... 200	D11
Default (2 × 25 % and 2 × 90 %) matched-pair calibration for DN 250 ... 600	D12
Default (2 × 25 % and 2 × 90 %) matched-pair calibration for DN 700 ... 1200	D13
5-point, matched-pair calibration for DN 15 ... 200 ¹⁾	D15
5-point, matched-pair calibr. for DN 250 ... 600 ¹⁾	D16

Selection and ordering data (continued)

	Order code
5-point, matched-pair calibr. for DN 700 ... 1200 ¹⁾	D17
10-point, matched-pair calibration for DN 15 ... 200 ²⁾	D18
10-point, matched-pair calibr. for DN 250 ... 600 ²⁾	D19
10-point, matched-pair calibr. for DN 700 ... 1200 ²⁾	D20
Accredited 5-point matched-pair calibration acc. to ISO 17025 DN 15 ... 200	D21
Accredited 5-point matched-pair calibration acc. to ISO 17025 DN 250 ... 600	D22
Accredited 5-point matched-pair calibration acc. to ISO 17025 DN 600 ... 1200	D23
Country of origin	
France	F55
Sensor cables	
Standard coil and electrode cable, PVC jacket	
• 5 m (16 ft)	K01
• 10 m (33 ft)	K02
• 20 m (65 ft)	K04
• 30 m (98 ft)	K06
• 40 m (131 ft)	K07
• 50 m (164 ft)	K08
• 60 m (197 ft)	K09
• 100 m (328 ft)	K10
• 150 m (492 ft)	K11
• 200 m (656 ft)	K12
• 500 m (1640 ft)	K13
Standard coil and special electrode cable, PVC jacket	
• 5 m (16 ft)	K51
• 10 m (33 ft)	K52
• 20 m (65 ft)	K54
• 30 m (98 ft)	K56
• 40 m (131 ft)	K57
• 50 m (164 ft)	K58
• 60 m (197 ft)	K59
• 100 m (328 ft)	K60
• 150 m (492 ft)	K61
• 200 m (656 ft)	K62
• 500 m (1640 ft)	K63
Terminal blocks	
Factory mounted terminal blocks	N02
Factory mounted terminal blocks, including wall-mounting kit	N03
Approval/Verification³⁾	
Without verification acc. to OIML R 49 (DN 50 ... 300)	P10
MI-001 Q3/Q1 = 40 (DN 50 ... 300)	P11
MI-001 Q3/Q1 = 63 (DN 50 ... 300)	P12
MI-001 Q3/Q1 = 80 (DN 50 ... 300)	P13
MI-001 Q3/Q1 = 160 (DN 50 ... 300)	P16
MI-001 Q3/Q1 = 200 (DN 50 ... 300)	P17
MI-001 Q3/Q1 = 250 (DN 50 ... 300)	P18
Without verification according to OIML R 49 (DN 350 ... 600)	P23

	Order code
MI-001 Q3/Q1 = 40 (DN 350 ... 600)	P24
MI-001 Q3/Q1 = 63 (DN 350 ... 600)	P25
MI-001 Q3/Q1 = 80 (DN 350 ... 600)	P26
MI-001 Q3/Q1 = 100 (DN 350 ... 600)	P27
Without verification according to OIML R 49 (DN 700 ... 1200)	P28
MI-001 Q3/Q1 = 40 (DN 700 ... 1200)	P29
MI-001 Q3/Q1 = 63 (DN 700 ... 1200)	P30
MI-001 Q3/Q1 = 80 (DN 700 ... 1200)	P31
PTB K7.2 QP/QI = 25 (DN 15 ... 300)	P41
PTB K7.2 QP/QI = 50 (DN 15 ... 300)	P42
PTB K7.2 QP/QI = 100 Lower range (DN 15 ... 300)	P43
PTB K7.2 QP/QI = 100 Upper range (DN 15 ... 300)	P44
PTB K7.2 QP/QI = 250 (DN 50 ... 300)	P45
PTB K7.2 QP/QI = 25 (DN 350 ... 600)	P47
PTB K7.2 QP/QI = 50 (DN 350 ... 600)	P48
PTB K7.2 QP/QI = 100 Lower range (DN 350 ... 600)	P49
Pulse output setting	
Volume / Pulse	
• 0.01 l/pulse	L01
• 0.1 l/pulse	L02
• 0.5 l/pulse	L03
• 1 l/pulse	L04
• 2.5 l/pulse	L05
• 5 l/pulse	L06
• 10 l/pulse	L07
• 25 l/pulse	L08
• 50 l/pulse	L09
• 100 l/pulse	L10
• 250 l/pulse	L11
• 500 l/pulse	L12
• 1 m ³ /pulse	L13
• 5 m ³ /pulse	L14
• 10 m ³ /pulse	L15
• 50 m ³ /pulse	L16
• 100 m ³ /pulse	L17
• 500 m ³ /pulse	L18
• 1000 m ³ /pulse	L19
Pulse width	
• 2 ms	L61
• 4.1 ms	L62
• 8.2 ms	L63
• 16 ms	L64
• 33 ms	L65
• 66 ms	L66
• 130 ms	L67
• 260 ms	L68

Flow Measurement

SITRANS FM (electromagnetic)

Flow sensors / SITRANS FM MAG 5100 W

Selection and ordering data (continued)

	Order code
• 520 ms	L69
FM Fire Service Approval (with ANSI B16.5 Class 150 flanges)	
DN 50, DN 80 and DN 100 (2", 3" and 4")	P20
DN 150 and DN 200 (6" and 8")	P21
DN 250 and DN 300 (10" and 12")	P22
Country specific label	
FP2E label (France)	H20
ADDC label (Abu Dhabi)	H23
CRN (Canadian Registration Number)	H25
Tag name plate	
Tag name plate transmitter, stainless steel (specify in plain text)	Y15
Tag name plate, stainless steel (specify in plain text)	Y17
Tag name plate, plastic (self-adhesive)	Y18

	Order code
Device settings	
Customer-specific transmitter setting	Y20
Factory mounted sensor cables	
Sensor cables wired	Y40
Sensor cables wired and IP68 sealing	Y41
Additional calibrations	
Customer-witnessed calibration (any of above calibration)	On request ⁴⁾

- 1) 20 %, 40 %, 60 %, 80 %, 100 % of factory Q_{max}
- 2) Ascending and descending at 20 %, 40 %, 60 %, 80 %, 100 % of factory Q_{max}
- 3) For more details and references of the ranges please see the tables under "Technical specifications"
- 4) Product Variation Request (PVR)

Accessories

Description	Article No.	
Potting kit for IP68/NEMA 6P sealing of sensor junction box	FDK:085U0220	

MAG 5000/6000 transmitters and sensors are packed in separate boxes, the final assembly takes place during installation at the customer's place. MAG 6000 I transmitters and sensors are delivered compact mounted from factory. Communication module will be pre-mounted in the transmitter.

Please use online Product selector to get latest updates.
<http://www.pia-portal.automation.siemens.com>

Technical specifications

Version	MAG 5100 W
Product characteristic	For demanding applications in the water & wastewater industry
Design and nominal size	Coned sensor (octagon liner): DN 15 ... 40 (½" ... 1½") Coned sensor: DN 50 ... 300 (2" ... 12") Full bore sensor: DN 350 ... 2000 (14" ... 80")
Measuring principle	Electromagnetic induction
Excitation frequency (mains supply: 50/60 Hz)	DN 15 ... 65 (½" ... 2½"): 12.5 Hz/15 Hz DN 80 ... 150 (3" ... 6"): 6.25 Hz/7.5 Hz DN 200 ... 300 (8" ... 12"): 3.125 Hz/3.75 Hz DN 350 ... 2000 (14" ... 80"): 1.5625 Hz/1.875 Hz
Process connection	
Flanges¹⁾	
• EN 1092-1	PN 6 (87 psi): DN 1400 ... 2000 (54" ... 80") Raised face ³⁾ PN 10 (145 psi): DN 200 ... 300 (8" ... 12") Flat face PN 10 (145 psi): DN 350 ... 1200 (14" ... 48") Raised face ³⁾ PN 16 (232 psi): DN 50 ... 300 (2" ... 12") Flat face ³⁾ PN 16 (232 psi): DN 350 ... 1200 (14" ... 48") Raised face PN 40 (580 psi): DN 15 ... 40 (½" ... 1½") Flat face
• ANSI B16.5	Class 150: ½" ... 12" Flat face; 14" ... 24" Raised face
• AWWA C-207	Class D: 28" ... 80", Flat face
• AS4087	PN 16 (232 psi): DN 50 ... 300 (2" ... 12") Flat Face PN 16 (232 psi): DN 350 ... 1200 (14" ... 48") Raised face
• JIS B 2220:2004	K10 (1" ... 24")
Rated operation conditions	
Ambient temperature	
• Sensor	-40 ... +70 °C (-40 ... +158 °F)
• Compact with transmitter	
- MAG 5000/6000 ⁴⁾	-20 ... +60 °C (-4 ... +140 °F)
- MAG 6000 I ⁵⁾	-20 ... +60 °C (-4 ... +140 °F)
Operating pressure (Abs) [abs. bar] (Maximum operating pressure depending on flange standard, decreases with increasing operating temperature)	DN 15 ... 40 (½" ... 1½"): 0.01 ... 40 bar (0.15 ... 580 psi) DN 50 ... 300 (2" ... 12"): 0.03 ... 20 bar (0.44 ... 290 psi) DN 350 ... 1200 (14" ... 48"): 0.01 ... 16 bar (0.15 ... 232 psi) DN 1400 ... 2000 (54" ... 80"): 0.01 ... 10 bar (0.15 ... 145 psi)
Enclosure rating	
• Standard	IP67 to EN 60529/NEMA 6 (1 mH ₂ O for 30 min)
• Option	IP68 to EN 60529/NEMA 6P (10 mH ₂ O continuously)
Pressure drop	DN 15 and 25 (½" and 1"): Max. 20 mbar (0.29 psi) at 1 m/s (3 ft/s) DN 40 ... 300 (1½" ... 12"): Max. 25 mbar (0.36 psi) at 3 m/s (10 ft/s) DN 350 ... 2000 (14" ... 80"): Insignificant
Test pressure	1.5 × PN (where applicable), FM Fire Service: 2 × PN
Mechanical load (vibration)	18 ... 1000 Hz random in x, y, z, directions for 2 hours according to EN 60068-2-36 Sensor: 3.17 g RMS Sensor with compact MAG 5000/6000 mounted transmitter: 3.17 g RMS Sensor with compact MAG 6000 I mounted transmitter: 1.14 g RMS

Version	MAG 5100 W
Medium conditions	
Temperature of medium	
• NBR	-10 ... +70 °C (14 ... 158 °F)
• EPDM	-10 ... +70 °C (14 ... 158 °F)
• EPDM (MI-001)	0.1 ... 30 °C (32 ... 76 °F)
• Ebonite	-
EMC	2014/30/EU
Design	
Material	
• Housing and flanges	Carbon steel ASTM A 105 with corrosion protection EN ISO 12944 grade C4 or C5 (durability up to 15 years) Hastelloy C276
• Electrode	Hastelloy C276
• Grounding electrode	Hastelloy C276
• Measuring pipe	Stainless steel AISI 304/1.4301
• Terminal box	Fibre glass reinforced polyamide
Certificates and approvals	
Calibration	
• Default calibration	Zero-point, 2 x 25 % and 2 x 90 %
• Special calibration	5-point calibration: 20 %, 40 %, 60 %, 80 %, 100 % of factory Q _{max} 10-point calibration: ascending and descending at 20 %, 40 %, 60 %, 80 %, 100 % of factory Q _{max} Matched pair calibration: default, 5-point or 10-point
Custody transfer	• MI-001 cold water (EU): DN 50 ... 2000 (2" ... 80") • Kiwa water approval (NL): DN 50 ... DN 1200 (2" ... 48") • Chilled water pattern approval PTB K 7.2 DN 15 ... 1200 (Germany) ⁶⁾
Drinking water	EPDM liner: • WRAS (WRC, BS6920 material approval for cold water, GB) • NSF/ANSI Standard 61 ⁷⁾ (Cold water, US) • ACS listed (France) • DVGW W270 (Germany) • Belgaqua (Belgium) • AS/NZS 4020 (Australia/New Zealand) • DNV
Marine⁸⁾	
Hazardous areas⁷⁾	
Standard sensor with/without MAG 5000/6000/6000 I	• FM - NI Class I Div. 2 Groups A, B, C, D ¹¹⁾ - NI Class I Zone 2 Groups IIC
Pressure equipment	• PED conforming: All EN1092-1 flanges and ANSI Class 150 (< DN 300 / < 12") – 2014/68/EU ⁹⁾
Others	• CRN (Canadian Registration Number) • EAC (Russia, Belarus, Kazakhstan) • FM Fire Service Meter acc. to class 1044 ¹⁰⁾ • VdS: Extinguishing systems DN 50 ... 300 • MCERTS (GB environmental)

¹⁾ DN 750, DN 1050 and DN 1100 (30", 42" and 44") not available with EN 1092-1 (PN 10 and PN 16) and AS4087 flanges

²⁾ Type 01 (SORF)

³⁾ DN ≤ 600 type 01 (SORF); DN > 600 type 11 (WNRF)

⁴⁾ Compact with transmitter MAG 5000 CT/6000 CT -20 ... +50 °C (-4 ... 122 °F)

⁵⁾ With HART communication max. ambient temperature 50 °C (122 °F)

⁶⁾ For verification submit Product Variation Request

⁷⁾ Including Annex G

⁸⁾ In remote version with sensor size DN 50 ... 300 (2" ... 12")

Flow Measurement

SITRANS FM (electromagnetic)

Flow sensors / SITRANS FM MAG 5100 W

Technical specifications (continued)

9) For sizes larger than 600 mm (24") in PN 16 PED conformity is available as a cost-added option. The basic unit will only carry the LVD (Low Voltage Directive) and EMC approval. All products sold outside of EU and EFTA are excluded from the directive, also products sold into certain market sectors are excluded. These include: (a) Meters used in networks for the supply, distribution and discharge of water; (b) Meters used in pipelines for the conveyance of any fluid from offshore to onshore; (c) Meters used in the extraction of petroleum or gas, including Christmas tree and manifold equipment; (d) Any meter mounted on a ship or mobile offshore platform. For further information on the PED standard and requirements see the section about Pressure Equipment Directive.

¹⁰⁾ Not for sensors with 300 µm coating

¹¹⁾ FM Class I Div. 2 not available for DN 15

MAG 5100 W (7ME6520) with MAG 6000 CT (Revenue program) MI-001

MAG 5100 W CT program is type approved according to international water meter standard OIML R 49. Since the first November 2006 the MI-001 water meter directive is in force, which means that all water

meters can be sold across the EU borders if the water meters contain a MI-001 label.

The MAG 5100 W MI-001 verified and labeled products are a Class II approval according to Directive 2014/32/EU of the European Parliament and Council of 26 February, 2014 on measuring instruments, Annex III Water meters (MI-001) in the sizes from DN 50 to DN 1200 (Article No. 7ME6520).

The MID certification is obtained as a modul B + D module approval according to the above mentioned directive.

Module B: Type approval according to OIML R 49

Module D: Quality insurance approval of production

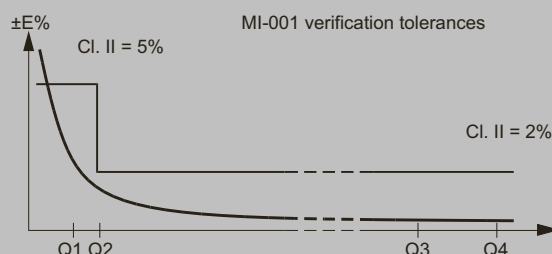

MAG 5100 W (7ME6520) with MAG 5000/MAG 6000 or MAG 6000 CT for Fire Service applications

MAG 5100 W (7ME6520) is FM Fire Service approved for automatic fire protection systems. The approval is applicable for the sizes DN 50,

DN 80, DN 100, DN 150, DN 200, DN 250 and DN 300 (2", 3", 4", 6", 8", 10" and 12") with ANSI B16.5 Class 150 flanges. The FM Fire Service approved product can be ordered via the Z-options P20, P21 and P22.

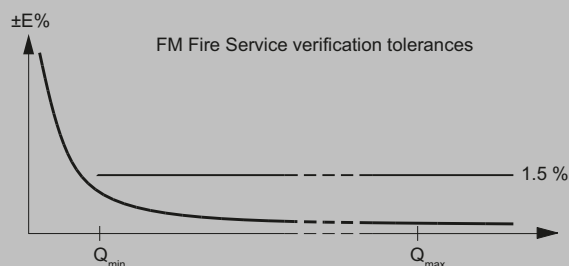

MI-001 approval

MAG 5100 W (7ME6520) MI-001 verified and labeled products at a given Q3 and Q3/Q4 = 1.25 and Q2/Q1 = 1.6 measuring ranges see table below:

Order code: P11	DN 50 (2")	DN 65 (2½")	DN 80 (3")	DN 100 (4")	DN 125 (5")	DN 150 (6")	DN 200 (8")	DN 250 (10")	DN 300 (12")
"R" Q3/Q1	40	40	40	40	40	40	40	40	40
Q4 [m³/h]	20	31.25	50	78.75	125	200	312.5	500	787.5
Q3 [m³/h]	16	25	40	63	100	160	250	400	630
Q2 [m³/h]	0.64	1.0	1.6	2.52	4.0	6.4	10.0	16.0	25.2
Q1 [m³/h]	0.4	0.63	1.0	1.58	2.5	4.0	6.25	10.0	15.75

Technical specifications (continued)

Order code: P12	DN 50 (2")	DN 65 (2½")	DN 80 (3")	DN 100 (4")	DN 125 (5")	DN 150 (6")	DN 200 (8")	DN 250 (10")	DN 300 (12")
"R" Q3/Q1	63	63	63	63	63	63	63	63	63
Q4 [m³/h]	20	31.25	50	78.75	125	200	312.5	500	787.5
Q3 [m³/h]	16	25	40	63	100	160	250	400	630
Q2 [m³/h]	0.41	0.63	1.02	1.6	2.5	4.1	6.3	10.2	16.0
Q1 [m³/h]	0.25	0.40	0.63	1.00	1.59	2.54	3.97	6.35	10.0

Order code: P13	DN 50 (2")	DN 65 (2½")	DN 80 (3")	DN 100 (4")	DN 125 (5")	DN 150 (6")	DN 200 (8")	DN 250 (10")	DN 300 (12")
"R" Q3/Q1	80	80	80	80	80	80	80	80	80
Q4 [m³/h]	20	31.3	50	78.75	125	200	312.5	500	787.5
Q3 [m³/h]	16	25	40	63	100	160	250	400	630
Q2 [m³/h]	0.32	0.5	0.8	1.26	2.0	3.2	5.0	8.0	12.6
Q1 [m³/h]	0.20	0.31	0.50	0.79	1.25	2.00	3.13	5.00	7.9

Order code: P16	DN 50 (2")	DN 65 (2½")	DN 80 (3")	DN 100 (4")	DN 125 (5")	DN 150 (6")	DN 200 (8")	DN 250 (10")	DN 300 (12")
"R" Q3/Q1	160	160	160	160	160	160	160	160	160
Q4 [m³/h]	50	78.5	125	200	312.5	500	787.5	1250	2000
Q3 [m³/h]	40	63	100	160	250	400	630	1000	1600
Q2 [m³/h]	0.4	0.63	1.0	1.6	2.5	4.0	6.3	10.0	16.0
Q1 [m³/h]	0.25	0.39	0.63	1.0	1.56	2.5	3.94	6.3	10.0

Order code: P17	DN 50 (2")	DN 65 (2½")	DN 80 (3")	DN 100 (4")	DN 125 (5")	DN 150 (6")	DN 200 (8")	DN 250 (10")	DN 300 (12")
"R" Q3/Q1	200	200	200	200	200	200	200	200	200
Q4 [m³/h]	50	78.5	125	200	312.5	500	787.5	1250	2000
Q3 [m³/h]	40	63	100	160	250	400	630	1000	1600
Q2 [m³/h]	0.32	0.50	0.80	1.28	2.0	3.2	5.0	8.0	12.8
Q1 [m³/h]	0.2	0.32	0.50	0.8	1.25	2.0	3.15	5.0	8.0

Order code: P18	DN 50 (2")	DN 65 (2½")	DN 80 (3")	DN 100 (4")	DN 125 (5")	DN 150 (6")	DN 200 (8")	DN 250 (10")	DN 300 (12")
"R" Q3/Q1	250	250	250	250	250	250	250	250	250
Q4 [m³/h]	50	78.5	125	200	312.5	500	787.5	1250	2000
Q3 [m³/h]	40	63	100	160	250	400	630	1000	1600
Q2 [m³/h]	0.26	0.4	0.64	1.02	1.6	2.56	4.0	6.4	10.24
Q1 [m³/h]	0.16	0.25	0.4	0.64	1.0	1.6	2.52	4.0	6.4

Order code: P24	DN 350 (14")	DN 400 (16")	DN 450 (18")	DN 500 (20")	DN 600 (24")
"R" Q3/Q1	40	40	40	40	40
Q4 [m³/h]	1250	1250	2000	2000	3125
Q3 [m³/h]	1000	1000	1600	1600	2500
Q2 [m³/h]	40.0	40.0	64.0	64.0	100.0
Q1 [m³/h]	25.0	25.0	40.0	40.0	62.5

Order code: P25	DN 350 (14")	DN 400 (16")	DN 450 (18")	DN 500 (20")	DN 600 (24")
"R" Q3/Q1	63	63	63	63	63
Q4 [m³/h]	1250	2000	3125	3125	5000
Q3 [m³/h]	1000	1600	2500	2500	4000
Q2 [m³/h]	25.4	40.63	63.49	63.49	101.6
Q1 [m³/h]	15.9	25.4	39.7	39.7	63.49

Order code: P26	DN 350 (14")	DN 400 (16")	DN 450 (18")	DN 500 (20")	DN 600 (24")
"R" Q3/Q1	80	80	80	80	80
Q4 [m³/h]	2000	3125	5000	5000	7875
Q3 [m³/h]	1600	2500	4000	4000	6300
Q2 [m³/h]	32.0	50.0	80.0	80.0	126.0
Q1 [m³/h]	20.0	31.25	50.0	50.0	78.75

Flow Measurement

SITRANS FM (electromagnetic)

Flow sensors / SITRANS FM MAG 5100 W

Technical specifications (continued)

Order code: P27	DN 350 (14")	DN 400 (16")	DN 450 (18")	DN 500 (20")	DN 600 (24")
"R" Q3/Q1	100	100	100	100	100
Q4 [m³/h]	3125	3125	5000	5000	7875
Q3 [m³/h]	2500	2500	4000	4000	6300
Q2 [m³/h]	40.0	2540.0	64.0	64.0	100.8
Q1 [m³/h]	25.0	25.0	40.0	40.0	63.0

Order code: P29	DN 700 (28")	DN 750 (30")	DN 800 (32")	DN 900 (36")	DN 1000 (40")	DN 1200 (48")
"R" Q3/Q1	40	40	40	40	40	40
Q4 [m³/h]	5000	5000	5000	7875	7875	7875
Q3 [m³/h]	4000	4000	4000	6300	6300	6300
Q2 [m³/h]	160.0	160.0	160.0	252.0	252.0	252.0
Q1 [m³/h]	100.0	100.0	100.0	157.5	157.5	157.5

Order code: P30	DN 700 (28")	DN 750 (30")	DN 800 (32")	DN 900 (36")	DN 1000 (40")	DN 1200 (48")
"R" Q3/Q1	63	63	63	63	63	-
Q4 [m³/h]	5000	5000	5000	7875	7875	-
Q3 [m³/h]	4000	4000	4000	6300	6300	-
Q2 [m³/h]	101.6	101.6	101.6	160.0	160.0	-
Q1 [m³/h]	63.5	63.5	63.5	100.0	100.0	-

Order code: P31	DN 700 (28")	DN 750 (30")	DN 800 (32")	DN 900 (36")	DN 1000 (40")	DN 1200 (48")
"R" Q3/Q1	80	80	80	80	80	-
Q4 [m³/h]	5000	5000	5000	7875	7875	-
Q3 [m³/h]	4000	4000	4000	6300	6300	-
Q2 [m³/h]	80.0	80.0	80.0	126.0	126.0	-
Q1 [m³/h]	50.0	50.0	50.0	78.75	78.75	-

The label is placed on the transmitter housing. An example of the product label is shown below:



MI-001 approval valid for:

- DN 50 to 2000 mm (2" to 80")
- Horizontal and vertical installation
- Compact or remote with max. 500 m cable
- Power supply 115 to 230 V AC, 12 to 24 V AC/DC

- With¹⁾ or without communication module
- Other restrictions may apply (see certificate).

Special MI-001 settings:

- Unit: m³
- Qmax: Q3
- Low flow cut-off: 0.1 %
- Digital output: Frequency

For other factory settings, see Operating Instructions.

PTB K7.2 approval

MAG 5100 W (7ME6520) PTB K7.2 verified and labeled products at a given Qp and Qs = 1.25 * Qp measuring ranges see table below:

Order code: P41	DN 15 (½")	DN 25 (1")	DN 40 (1½")	DN 50 (2")	DN 65 (2½")	DN 80 (3")	DN 100 (4")	DN 125 (5")	DN 150 (6")	DN 200 (8")	DN 250 (10")	DN 300 (12")
Qp/Qi	25	25	25	25	25	25	25	25	25	25	25	25
Qs [m³/h]	1.90	4.40	12.50	20	31.25	50	78.75	125	200	312.50	500	787.50
Qp [m³/h]	1.5	3.5	10	16	25	40	63	100	160	250	400	630
Qi [m³/h]	0.06	0.14	0.40	0.64	1	1.60	2.52	4	6.40	10	16	25.20

Technical specifications (continued)

Order code: P42	DN 15 (½")	DN 25 (1")	DN 40 (1½")	DN 50 (2")	DN 65 (2½")	DN 80 (3")	DN 100 (4")	DN 125 (5")	DN 150 (6")	DN 200 (8")	DN 250 (10")	DN 300 (12")
Qp/Qi	50	50	50	50	50	50	50	50	50	50	50	50
Qs [m³/h]	2.50	4.40	12.50	20	31.25	50	78.75	125	200	312.50	500	787.50
Qp [m³/h]	2	3.5	10	16	25	40	63	100	160	250	400	630
Qi [m³/h]	0.04	0.07	0.20	0.32	0.50	0.80	1.26	2	3.20	5	8	12.60

Order code: P43	DN 15 (½")	DN 25 (1")	DN 40 (1½")	DN 50 (2")	DN 65 (2½")	DN 80 (3")	DN 100 (4")	DN 125 (5")	DN 150 (6")	DN 200 (8")	DN 250 (10")	DN 300 (12")
Qp/Qi	100	100	100	100	100	100	100	100	100	100	100	100
Qs [m³/h]	5	5	12.50	20	31.25	50	78.75	125	200	312.50	500	787.50
Qp [m³/h]	4	4	10	16	25	40	63	100	160	250	400	630
Qi [m³/h]	0.04	0.04	0.10	0.16	0.25	0.40	0.63	1	1.60	2.50	4	6.30

Order code: P44	DN 15 (½")	DN 25 (1")	DN 40 (1½")	DN 50 (2")	DN 65 (2½")	DN 80 (3")	DN 100 (4")	DN 125 (5")	DN 150 (6")	DN 200 (8")	DN 250 (10")	DN 300 (12")
Qp/Qi	100	100	100	100	100	100	100	100	100	100	100	100
Qs [m³/h]	5	5	12.50	20	31.25	50	78.75	125	200	312.50	500	787.50
Qp [m³/h]	4	4	10	16	25	40	63	100	160	250	400	630
Qi [m³/h]	0.04	0.04	0.10	0.16	0.25	0.40	0.63	1	1.60	2.50	4	6.30

Order code: P45	DN 50 (2")	DN 65 (2½")	DN 80 (3")	DN 100 (4")	DN 125 (5")	DN 150 (6")	DN 200 (8")	DN 250 (10")	DN 300 (12")
Qp/Qi	250	250	250	250	250	250	250	250	250
Qs [m³/h]	79	78.75	125	200	313	500	787.50	1250	2000
Qp [m³/h]	63	63	100	160	250	400	630	1000	1600
Qi [m³/h]	0.25	0.25	0.40	0.64	1	1.60	2.52	4	6.40

Order code: P47	DN 350 (14")	DN 400 (16")	DN 450 (18")	DN 500 (20")	DN 600 (24")
Qp/Qi	25	25	25	25	25
Qs [m³/h]	1250	2000	3125	3125	5000
Qp [m³/h]	1000	1600	2500	2500	4000
Qi [m³/h]	40	64	100	100	160

Order code: P48	DN 350 (14")	DN 400 (16")	DN 450 (18")	DN 500 (20")	DN 600 (24")
Qp/Qi	50	50	50	50	50
Qs [m³/h]	1250	2000	3125	3125	5000
Qp [m³/h]	1000	1600	2500	2500	4000
Qi [m³/h]	20	32	50	50	80

Order code: P49	DN 350 (14")	DN 400 (16")	DN 450 (18")	DN 500 (20")	DN 600 (24")
Qp/Qi	100	100	100	100	100
Qs [m³/h]	2000	3125	5000	5000	5000
Qp [m³/h]	1000	1600	2500	2500	4000
Qi [m³/h]	40	64	100	100	160

The label is placed on the transmitter housing. An example of the product label is shown below:



PTB K7.2 approval valid for:

- DN 15 to 1200 mm (½" to 48")
 - Horizontal and vertical installation
 - Compact or remote with max. 500 m cable
 - Power supply 115 to 230 V AC, 12 to 24 V AC/DC
 - With¹⁾ or without communication module
- Other restrictions may apply (see certificate).
Special PTB K7.2 settings:
- Qmax: Qs
 - Current output: 4 ... 20 mA

Flow Measurement

SITRANS FM (electromagnetic)

Flow sensors / SITRANS FM MAG 5100 W

Technical specifications (continued)

For other factory settings, see Operating Instructions.

Dimensional drawings

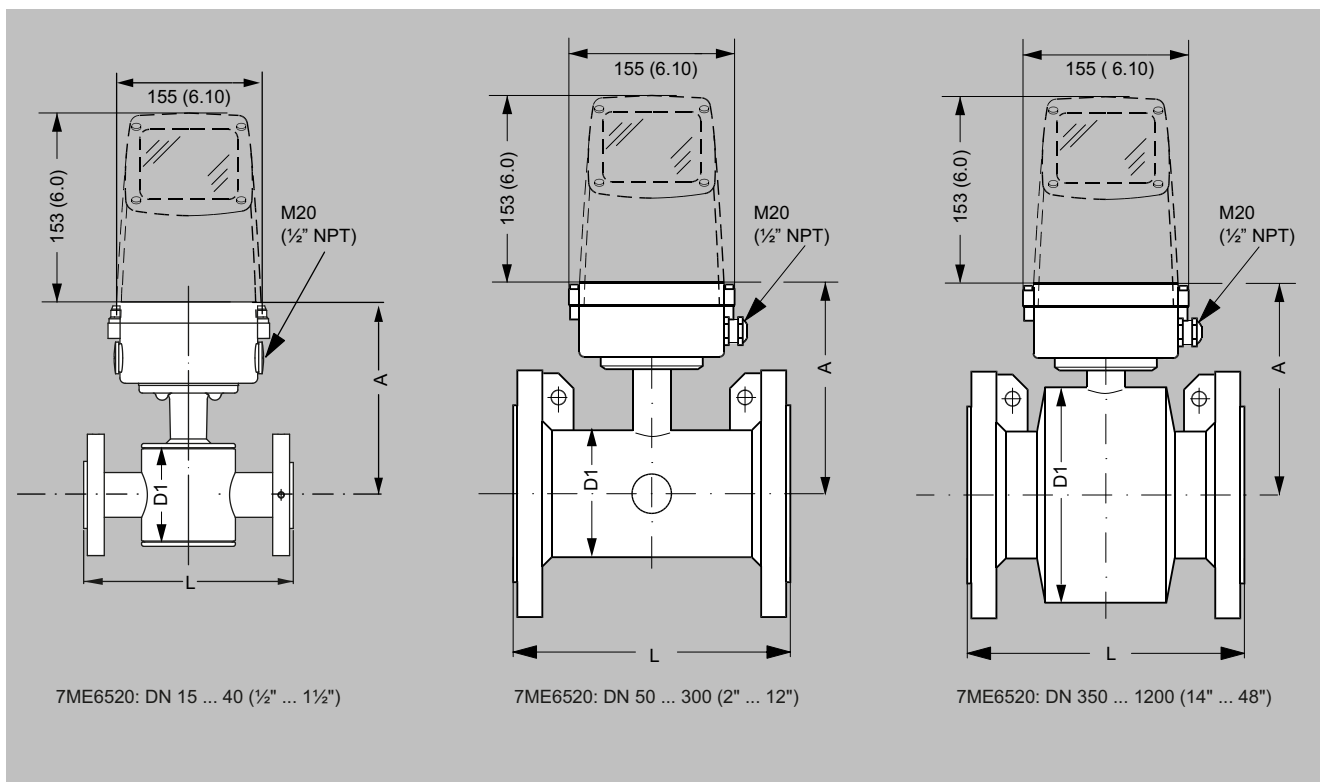

Nominal size		7ME6520 NBR or EPDM liner				L ¹⁾	
[mm]	[inch]	A [mm]	[inch]	D1 [mm]	[inch]	[mm]	[inch]
15	1/2	177	7.0	77	3.0	200	7.9
25	1	187	7.4	96	3.8	200	7.9
40	1 1/2	202	8.0	127	5.0	200	7.9
50	2	188	7.4	76	3.0	200	7.9
65	2 1/2	194	7.6	89	3.5	200	7.9
80	3	200	7.9	102	4.0	200	7.9
100	4	207	8.1	114	4.5	250	9.8
125	5	217	8.5	140	5.5	250	9.8
150	6	232	9.1	168	6.6	300	11.8
200	8	257	10.1	219	8.6	350	13.8
250	10	284	11.2	273	10.8	450	17.7
300	12	310	12.2	324	12.8	500	19.7
350	14	382	15.0	451	17.8	550	21.7
400	16	407	16.0	502	19.8	600	23.6
450	18	438	17.2	563	22.2	600	23.6
500	20	463	18.2	614	24.2	600	23.6
600	24	514	20.2	715	28.2	600	23.6
700	28	564	22.2	816	32.1	700	27.6
750	30	591	23.3	869	34.2	750	29.5
800	32	616	24.3	927	36.5	800	31.5
900	36	663	26.1	1032	40.6	900	35.4

Dimensional drawings (continued)

Nominal size [mm]	7ME6520 NBR or EPDM liner						L ¹⁾	
	[inch]	A [mm]	[inch]	D1 [mm]	[inch]	[mm]	[inch]	
1000	40	714	28.1	1136	44.7	1000	39.4	
	42	714	28.1	1136	44.7	1000	39.4	
	44	765	30.1	1238	48.7	1100	43.3	
1200	48	820	32.3	1348	53.1	1200	47.2	
1400	54	925	36.4	1574	65.94	1400	55.1	
1500	60	972	38.2	1672	65.83	1500	59.1	
1600	66	1025	40.4	1774	75.39	1600	63.0	
1800	72	1123	44.2	1974	77.72	1800	70.9	
2000	80	1223	48.1	2174	85.59	2000	78.7	

1) Tolerances on built-in length:

DN 15 to DN 200 (½" to 8"): +0/-3 mm (+0/-0.12"), DN 250 to DN 400 (10" to 16"): +0/-5 mm (+0/-0.20"),

DN 450 to DN 600 (18" to 24"): +5/-5 mm (+0.20/-0.20"), DN 700 to DN 2000 (28" to 78"): +10/-10 mm (+0.39/-0.39")

MAG 5100 W/6000 I Compact

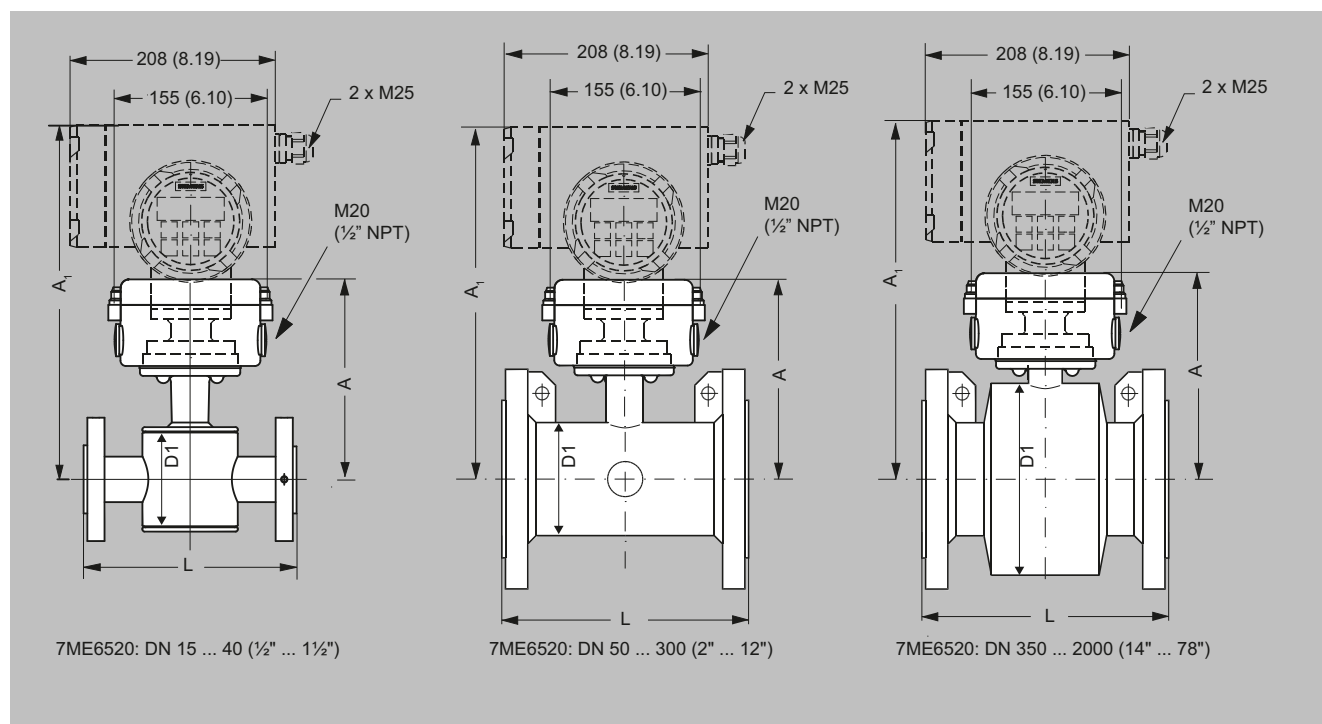

Nominal size [mm]	7ME6520 NBR or EPDM liner									
	[inch]	A [mm]	[inch]	A1 [mm]	[inch]	D1 [mm]	[inch]	L ¹⁾ [mm]	[inch]	
15	½	177	7.0	331	13.0	77	3.0	200	7.9	
25	1	187	7.4	341	13.4	96	3.8	200	7.9	
40	1½	202	8.0	356	14.0	127	5.0	200	7.9	
50	2	188	7.4	342	13.5	76	3.0	200	7.9	
65	2½	194	7.6	348	13.7	89	3.5	200	7.9	
80	3	200	7.9	354	14.0	102	4.0	200	7.9	
100	4	207	8.1	361	14.2	114	4.5	250	9.8	
125	5	217	8.5	371	14.6	140	5.5	250	9.8	
150	6	232	9.1	386	15.2	168	6.6	300	11.8	
200	8	257	10.1	411	16.2	219	8.6	350	13.8	
250	10	284	11.2	438	17.2	273	10.8	450	17.7	
300	12	310	12.2	464	18.3	324	12.8	500	19.7	

Flow Measurement

SITRANS FM (electromagnetic)

Flow sensors / SITRANS FM MAG 5100 W

Dimensional drawings (continued)

Nominal size		7ME6520 NBR or EPDM liner				D1		L ¹⁾	
[mm]	[inch]	A [mm]	[inch]	A1 [mm]	[inch]	[mm]	[inch]	[mm]	[inch]
350	14	382	15.0	536	21.1	451	17.8	550	21.7
400	16	407	16.0	561	22.1	502	19.8	600	23.6
450	18	438	17.2	592	23.3	563	22.2	600	23.6
500	20	463	18.2	617	24.3	614	24.2	600	23.6
600	24	514	20.2	668	26.3	715	28.2	600	23.6
700	28	564	22.2	718	28.3	816	32.1	700	27.6
750	30	591	23.3	745	29.3	869	34.2	750	29.5
800	32	616	24.3	770	30.3	927	36.5	800	31.5
900	36	663	26.1	817	32.2	1032	40.6	900	35.4
1000	40	714	28.1	868	34.2	1136	44.7	1000	39.4
	42	714	28.1	868	34.2	1136	44.7	1000	39.4
	44	765	30.1	919	36.2	1238	48.7	1100	43.3
1200	48	820	32.3	974	38.3	1348	53.1	1200	47.2
1400	54	925	36.4	1079	42.5	1574	61.97	1400	55.1
1500	60	972	38.2	1126	44.3	1672	65.83	1500	59.1
1600	66	1025	40.4	1179	46.4	1774	59.84	1600	63.0
1800	72	1123	44.2	1277	50.3	1974	77.72	1800	70.9
2000	80	1223	48.1	1377	54.2	2174	85.59	2000	78.7

¹⁾ Tolerances on built in length:

DN 15 to DN 200 (½" to 8"): +0/-3 mm (+0/-0.12"), DN 250 to DN 400 (10" to 16"): +0/-5 mm (+0/-0.20")

DN 450 to DN 600 (18" to 24"): +5/-5 mm (+0.20/-0.20"), DN 700 to DN 2000 (28" to 78"): +10/-10 mm (+0.39/-0.39")

Nominal size		7ME6520		PN 10		PN 16		PN 40		Class 150		AWWA C-207		AS 4087		JIS10K	
[mm]	[inch]	[kg]	[lbs]	[kg]	[lbs]	[kg]	[lbs]	[kg]	[lbs]	[kg]	[lbs]	[kg]	[lbs]	[kg]	[lbs]	[kg]	[lbs]
15	½	-	-	-	-	5	11	5	11	-	-	-	-	5	11	-	-
25	1	-	-	-	-	6	13	6	13	-	-	-	-	6	13	-	-
40	1½	-	-	-	-	9	20	9	20	-	-	-	-	9	20	-	-
50	2	-	-	10	22	-	-	10	22	-	-	10	22	10	22	-	-
65	2½	-	-	12	26	-	-	12	26	-	-	12	26	12	26	-	-
80	3	-	-	13	29	-	-	13	29	-	-	13	29	13	29	-	-
100	4	-	-	17	37	-	-	18	40	-	-	17	37	17	37	-	-
125	5	-	-	20	44	-	-	21	46	-	-	-	-	20	44	-	-
150	6	-	-	27	60	-	-	30	66	-	-	21	57	26	57	-	-
200	8	38	84	39	86	-	-	47	104	-	-	64	106	35	77	-	-
250	10	51	115	56	123	-	-	64	141	-	-	48	152	51	112	-	-
300	12	62	137	72	159	-	-	92	203	-	-	61	189	59	130	-	-
350	14	99	218	115	254	-	-	131	289	-	-	106	254	88	194	-	-
400	16	121	267	143	315	-	-	161	355	-	-	124	277	113	249	-	-
450	18	144	317	177	390	-	-	182	401	-	-	145	311	135	298	-	-
500	20	165	364	222	489	-	-	217	478	-	-	175	418	151	333	-	-
600	24	225	496	321	708	-	-	305	672	-	-	285	664	179	395	-	-
700	28	272	600	331	730	-	-	-	-	284	626	350	704	-	-	-	-
750	30	-	-	-	-	-	-	-	-	331	730	-	-	-	-	-	-
800	32	300	661	386	851	-	-	-	-	394	869	485	944	-	-	-	-
900	36	372	820	482	1063	-	-	-	-	487	1074	645	1362	-	-	-	-
1000	40	454	1001	672	1482	-	-	-	-	589	1299	696	1399	-	-	-	-
	42	-	-	-	-	-	-	-	-	693	1528	-	-	-	-	-	-
	44	-	-	-	-	-	-	-	-	774	1706	-	-	-	-	-	-
1200	48	728	1605	1116	2460	-	-	-	-	916	2019	1116	1789	-	-	-	-
1400	56	1338	2944	1592	3502	1890	4158	-	-	-	-	1592	3502	-	-	-	-
1500	60	1520	3344	1850	4070	2238	4924	-	-	-	-	1950	4290	-	-	-	-
1600	64	1696	3731	2110	4642	2525	5555	-	-	-	-	2110	4642	-	-	-	-
1800	72	2110	4642	2560	5632	3460	7612	-	-	-	-	2560	5632	-	-	-	-
2000	80	2564	5641	3640	8008	4205	9251	-	-	-	-	3640	8008	-	-	-	-